

® KÉSZÍTSENLENYŰGÖZŐ TEREKET™

# MANUAL

# NEWTON™ 759

USER MANUAL | MODE D'EMPLOI | MANUAL DEL USUARIO | GEBRAUCHSANLEITUNG |  
GEBRUIKSHANDLEIDING | MANUALE PER L'UTENTE | MANUAL DO UTILIZADOR | ÖSSZESZERELÉSI ÚTMUTATÓ

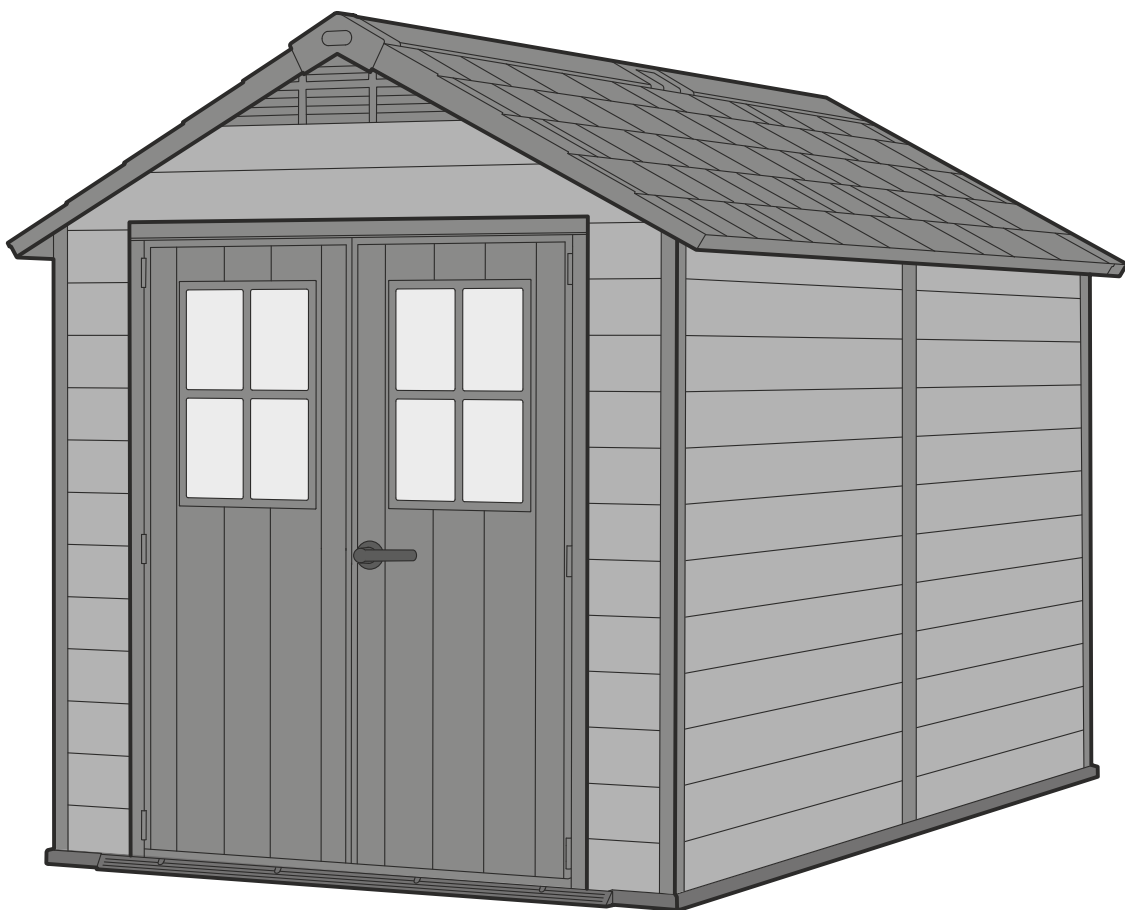

**IMPORTANT | IMPORTANT | FONTOS**

RETAIN FOR FUTURE REFERENCE: READ CAREFULLY

À CONSERVER POUR DE FUTURS BESOINS DE RÉFÉRENCE : À LIRE SOIGNEUSEMENT

KÖVESSE A SZERELÉSI ÚTMUTATÓT. OLVASSA EL FIGYELMESEN

For outdoor use only. Not for commercial use | Utilisation non commerciale à l'extérieur seulement |  
Kívül használatra. Nem kereskedelmi célra.

**Level the ground surface | Nivelez la surface du sol | Nivele la superficie del suelo | Ebenen Sie die Bodenoberfläche | Maak de bodemvlak | Livella la superficie del terreno | A talaj felületét egyengesse**

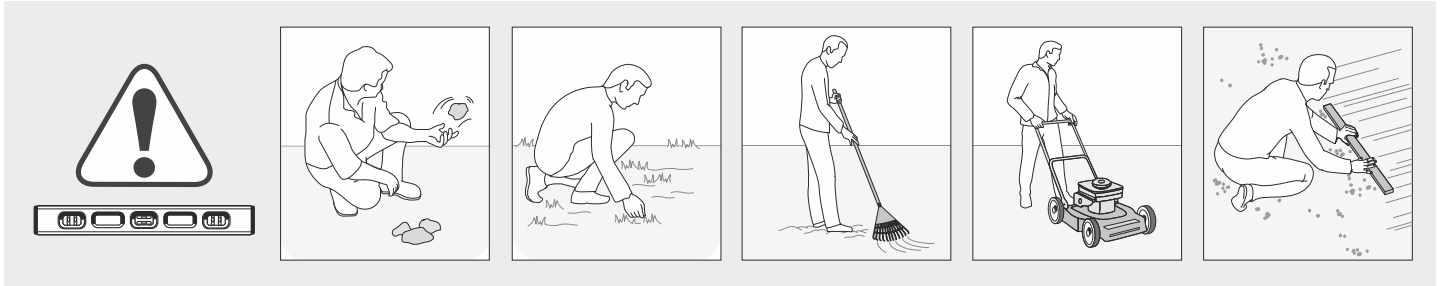

**Recommendation: Construct a wooden or concrete base as a foundation | Recommandation: fabriquez une base en bois ou en béton en guise de fondation | Recomendación: construya una base de madera o de cemento a modo de cimiento | Empfehlung: Bauen Sie als Fundament eine Grundfläche aus Holz oder Beton | Aanbeveling: maak een houten of betonnen ondergrond als fundering | Raccomandazione: costruisci una base di legno o di cemento come fondamenta | Javaslat: Építsen fa vagy cement alapot alapként**

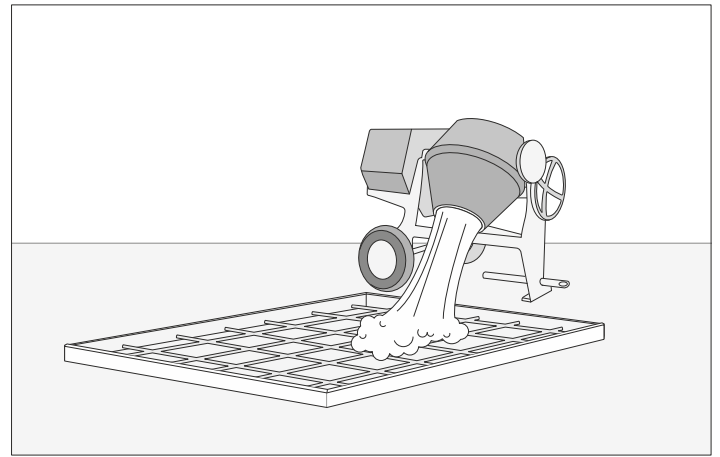
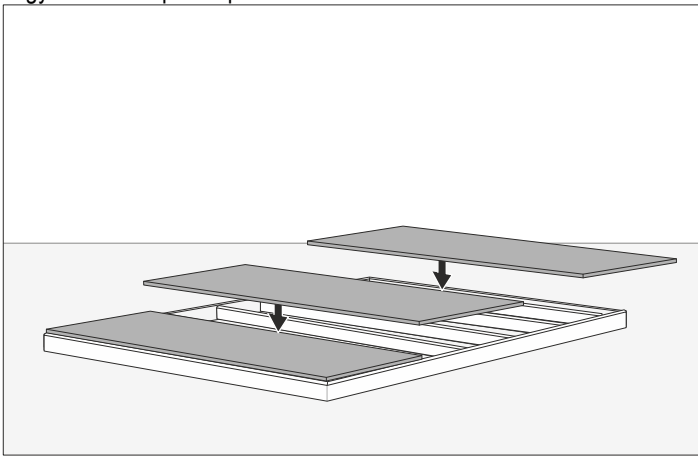

For external access during assembly, make sure to leave enough room around the outside of the shed assembly site.

Pour un accès externe au cours du montage, veillez à laisser suffisamment de place autour du site de montage.

Para tener un acceso exterior durante el montaje, asegúrese de dejar suficiente espacio alrededor del lugar de montaje del cobertizo.

Lassen Sie am Aufstellungsort außerhalb des Schuppens ausreichend Platz, so dass Sie während des Aufbaus von außen Zugang zum Schuppen haben.

Om tijdens de montage aan de buitenkant van het schuurtje te kunnen werken, moet u ervoor zorgen dat u genoeg ruimte laat aan de buitenkant van de montageplaats.

Per l'accesso esterno durante il montaggio, assicurati di lasciare abbastanza spazio intorno alla parte esterna del luogo di montaggio del deposito attrezzi.

Az összeszerelés során a külső hozzáférés érdekében ügyeljen arra, hogy elegendő helyet hagyjon a ház felszerelési helyének külső része körül.

**External floor measurements are: | Mesures externes du plancher: | Las medidas del suelo externo son: | Die Außen-Bodenmaße betragen: | De afmetingen van de externe vloer zijn: | Le misure del pavimento esterno sono:**

**| A padló külső intézkedései:**

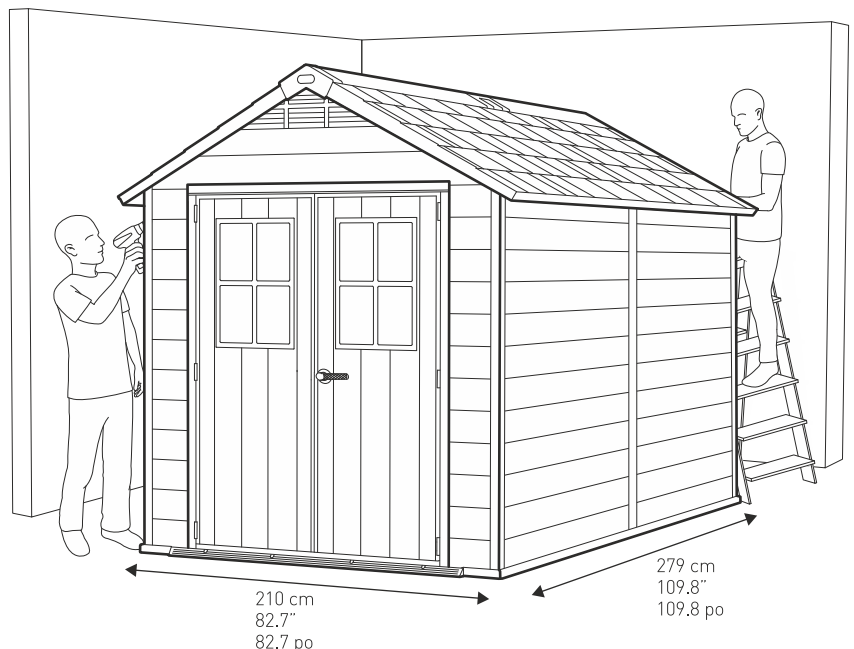

**BEFORE STARTING ASSEMBLY | AVANT DE COMMENCER LE MONTAGE | ANTES DE EMPEZAR EL ARMADO | VOR MONTAGEBEGINN | VOORDAT U BEGINT TE MONTEREN | PRIMA DI INIZIARE IL MONTAGGIO | AZ ÖSSZESZERELÉS MEGKEZDÉSE ELŐTT**

**Read the care and safety guidelines at the end of this manual | Check to ensure that there are no missing or damaged parts BEFORE starting or arranging assembly | Remove all parts from the package(s) and spread them out on a clean work surface | Review all assembly instructions | Assemble all the parts according to the directions in this manual. Do not skip any steps.**

Lisez les instructions de précaution et de sécurité à la fin de ce manuel | Assurez-vous qu'il n'y a pas de pièces manquantes ou endommagées AVANT de commencer ou d'organiser l'assemblage | Retirez toutes les pièces du/des paquet(s) et étalez-les sur une surface de travail propre | Lisez toutes les instructions de montage | Assemblez toutes les pièces selon les instructions de ce manuel. Ne sautez aucune étape.

**Lea las instrucciones de precauciones y seguridad que están al final de este manual | Asegúrese de que no faltan piezas ni están dañadas ANTES de comenzar o disponer el montaje | Saque todas las piezas del paquete o paquetes y póngalas sobre una superficie de trabajo limpia | Revise todas las instrucciones de montaje | Monte todas las piezas según las instrucciones de este manual. No se saltee ningún paso.**

Lesen Sie die Sicherheitsrichtlinien am Ende des Benutzerhandbuchs durch | Prüfen Sie bitte VOR dem Zusammenbau, dass keine Teile beschädigt sind oder fehlen | Nehmen Sie alle Teile aus der Verpackung und breiten Sie sie auf einer sauberen Arbeitsfläche aus | Gehen Sie noch einmal die komplette Aufbauanleitung durch | Bauen Sie alle Teile entsprechend der Anleitung in diesem Handbuch zusammen. Lassen Sie dabei keinen Arbeitsschritt aus.

**Lees de richtlijnen voor zorg en veiligheid achterin deze handleiding | Controleer dat er geen onderdelen mankeren, of beschadigd zijn, VOORDAT u met de montage begint | Haal alle onderdelen uit het pakket (of uit de pakketten) en leg ze opeen schoon werkoppervlak | Bekijk alle montagehandleidingen | Monteer alle onderdelen volgens de aanwijzingen van deze handleiding. Sla geen stappen over.**

Leggi le linee guida di assistenza e sicurezza alla fine di questo manuale | Verificare per assicurarsi che non ci siano parti mancanti o danneggiate PRIMA di iniziare o di disporre il montaggio | Rimuovi tutti i componenti dal pacchetto (i) e spargili su una superficie di lavoro pulita | Consulta tutte le istruzioni di montaggio | Monta tutti i componenti secondo le istruzioni contenute in questo manuale. Non saltare nessuna fase.

**Leia as diretrizes de cuidados e segurança que constam da parte final deste manual | Verifique para se assegurar de que não há peças em falta ou danificadas ANTES de começar a preparar a montagem | Retire todas as peças da embalagem e espalhe-as numa superfície de trabalho limpa | Reveja todas as instruções de montagem | Szerelje össze az összes alkatrészt a kézikönyv utasításainak megfelelően. Ne hagyjon ki egyetlen lépést sem.**

**REQUIRED TOOLS | OUTILS EXIGÉS | HERRAMIENTAS NECESARIAS | BENÖTIGTE WERKZEUGE | BENODIGD GEREEDSCHAP | ATTREZZATURA OCCORRENTE | SZÜKSÉGES ESZKÖZÖK**



**ASSEMBLY REQUIRES TWO PEOPLE | LE MONTAGE DOIT ÊTRE EFFECTUÉ PAR DEUX PERSONNES | SE NECESITAN DOS PERSONAS PARA ARMARLO | ZWEI PERSONEN ZUR MONTAGE NOTWENDIG | MONTAGE VEREIST TWEE PERSONEN | MONTAGGIO RICHIEDE DUE PERSONE | ÖSSZESZERELÉSHEZ SZÜKSÉGES KÉT EMBER**

**Remove all parts from the package(s) and spread them out on a clean work surface | Code letters are imprinted on each part for easy identification | Retirez toutes les pièces du/des paquet(s) et étalez-les sur une surface de travail propre | Des lettres sont imprimées sur chaque pièce pour une identification facile | Saque todas las piezas del paquete o paquetes y póngalas sobre una superficie de trabajo limpia | El código de letras está marcado en cada pieza para que sea más fácil identificarla | Nehmen Sie alle Teile aus der Verpackung und breiten Sie sie auf einer sauberen Arbeitsfläche aus | Auf jedem Teil sind Kennbuchstaben aufgedruckt, die die Zuordnung der einzelnen Teile erleichtern | Haal alle onderdelen uit het pakket (of uit de pakketten) en leg ze op een schoon werkoppervlak | Op ieder onderdeel zijn codes aangebracht voor een gemakkelijke identificatie | Rimuovi tutti i componenti dal pacchetto (i) e spargili su una superficie di lavoro pulita | Le lettere del codice sono state stampate su ciascun componente per una facile identificazione | Retire todas as peças da embalagem e espalhe-as numa superfície de trabalho limpa | Minden részre kódbetűk vannak nyomtatva az egyszerű azonosítás érdekében**

**FLOOR PARTS | ÉLÉMENTS DU PLANCHER | PARTES DEL SUELO | BODENTEILE | VLOERPANELEN | PARTI DEL PAVIMENTO | PADLÓRÉSZEK**

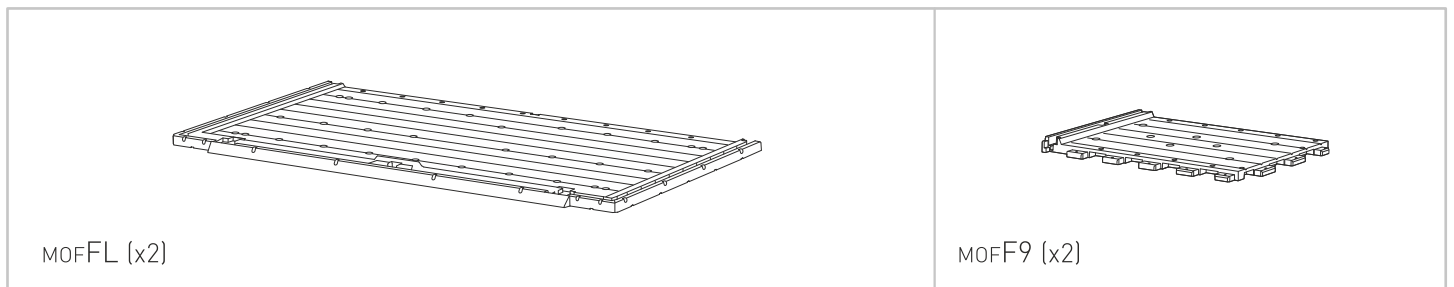

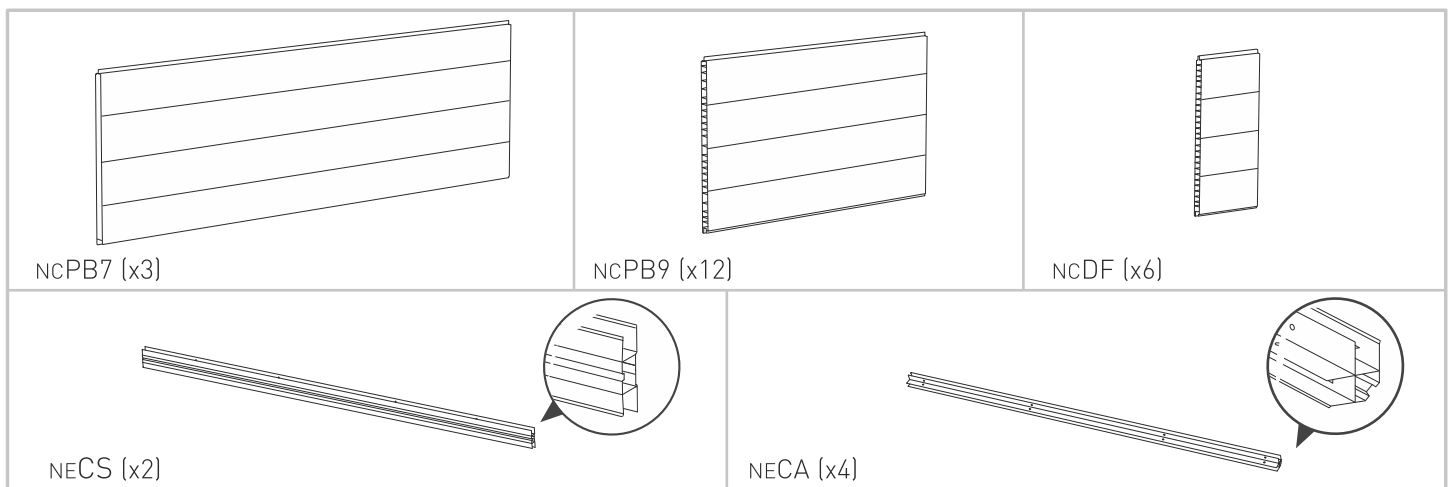

**WALL PARTS | PIÈCES DES MURS | PARTES DE LAS PAREDES | WANDELEMENTE | MUURONDERDELEN | PARTI DELLA PARETE | OLDALPANELEK**



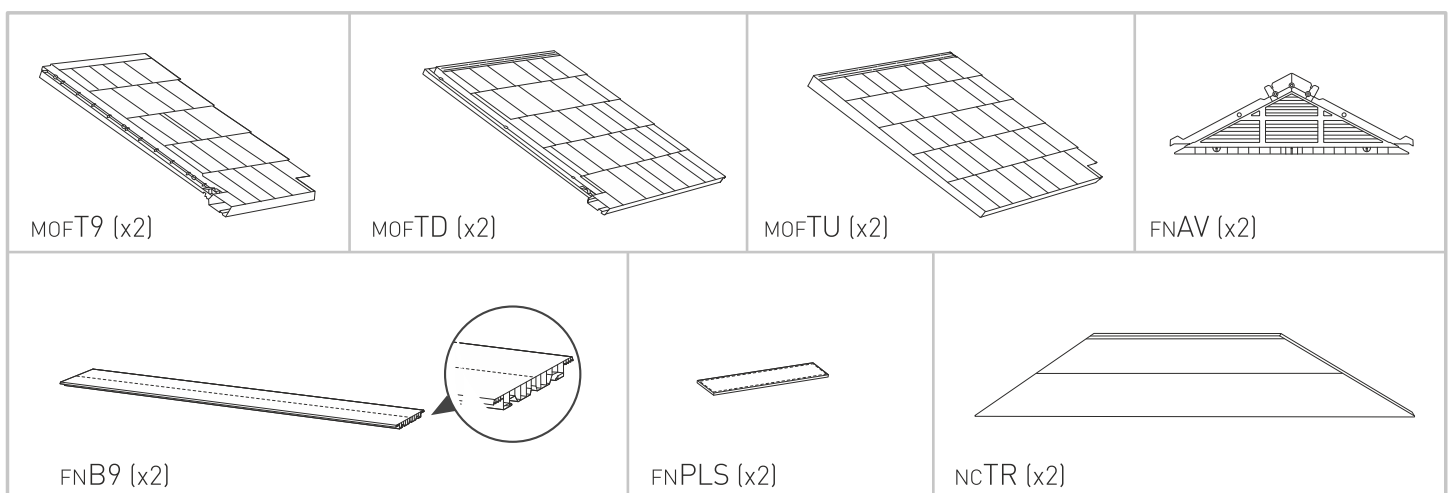



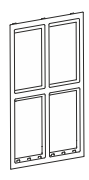
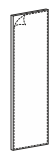



**ROOF PARTS | PIÈCES DU TOIT | PARTES DEL TECHO | DACHELEMENTE | DAKONDERDELEN | PARTI DEL TETTO | TETŐRÉSZEK**

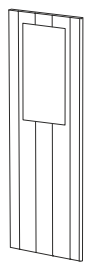
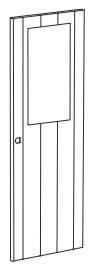

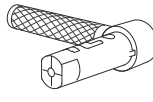
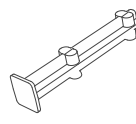









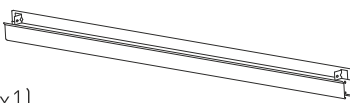
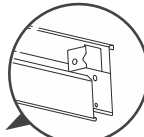

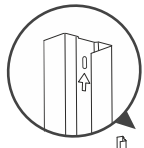

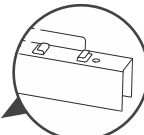
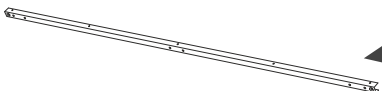
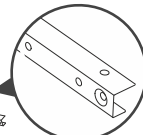

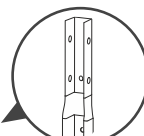
**WINDOW PARTS | PIÈCES DE LA FENÊTRE | PARTES DE LA VENTANA | FENSTERELEMENTE | VENSTERONDERDELEN | PARTI DELLA FINESTRA | ABLAK ALKATRÉSZEK**

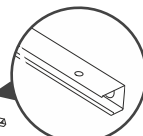
 <p>smWF (x2)</p>	 <p>smWG (x4)</p>	 <p>moWB (x2)</p>
--	--	--

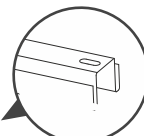

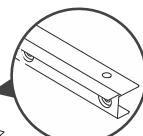
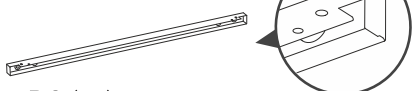
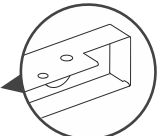
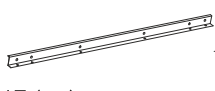
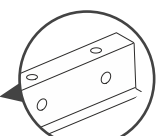

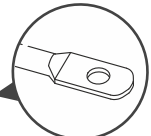
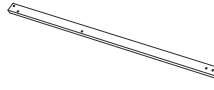
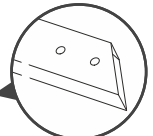
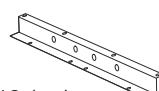
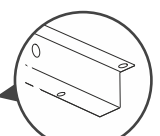
**DOOR PARTS | PIÈCES DE LA PORTE | PARTES DE LA PUERTA | TÜRELEMENTE | DEURONDERDELEN | PARTI DELLA PORTA | AJ TÓRÉSZEK**

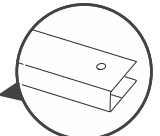
 <p>neDDL (x1)</p>	 <p>neDDR (x1)</p>	 <p>nuHE (x1)</p>	 <p>nuHA (x1)</p>	 <p>nuHF (x2)</p>	 <p>nuHD (x1)</p>
		 <p>nuHG (x2)</p>	 <p>nuHH (x2)</p>	 <p>nuHB (x1)</p>	 <p>nuHC (x1)</p>

**METAL PARTS | PIÈCES MÉTALLIQUES | PIEZAS METÁLICAS | METALLTEILE | METALEN DELEN | PARTI IN METALLO | FÉMÉRÉSZEK**

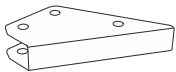
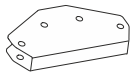
 <p>neUK (x1)</p>		 <p>neFM (x1)</p>	
 <p>neLR (x2)</p>		 <p>neDS0 (x2)</p>	
 <p>neMS (x2)</p>		 <p>neDS1 (x1)</p>	
 <p>neMBA (x1)</p>		 <p>neDSW (x1)</p>	
 <p>neDC (x4)</p>		 <p>moFM7 (x4)</p>	
 <p>neMB (x2)</p>		 <p>moSF (x2)</p>	
		 <p>moFM9 (x4)</p>	
		 <p>fnMH (x1)</p>	

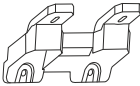
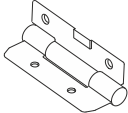
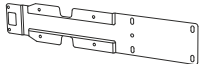
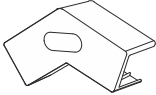
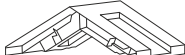
**SMALL PARTS | PETITES PIÈCES | PARTES PEQUEÑAS | KLEINTEILE | KLEINE ONDERDELEN | MINUTERIA | KI S RÉSZEK**

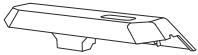
					
FNME (x2)	FNMA (x1)	FNTM (x4)	MoFTC (x4)	NEDH (x6)	NETPR (x2)
					
FNAC (x2)	FNBC9 (x1)	NEDMC (x8)	NEDPC (x2)	NEDT (x1)	

**SCREWS | VIS | TORNILLOS | SCHRAUBEN | SCHROEVEN | VITI | CSAVAROK**

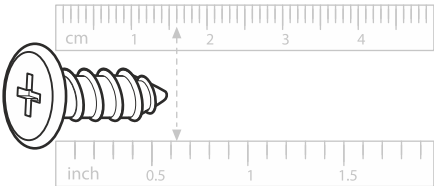
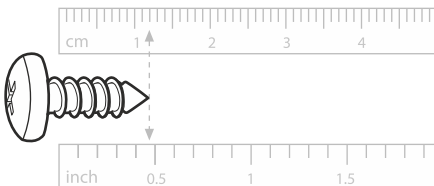
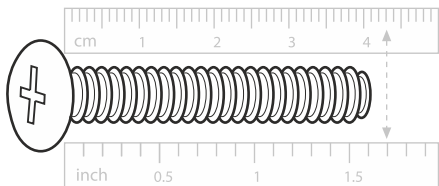
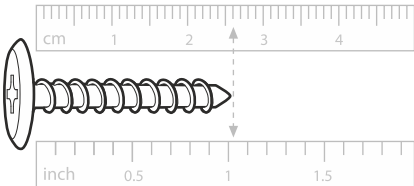
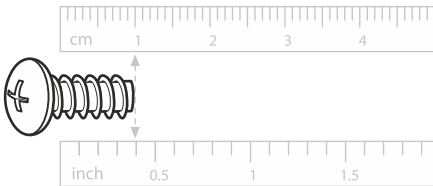
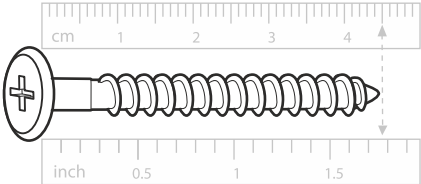
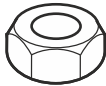
 sc15 (x234) 16 mm / 0.63"	 S13b (x120) 12 mm / 0.47"	 sc8 (x13) 43 mm / 1.69"
 S26b (x8) 26 mm / 1"	 sf13 (x16) 10 mm / 0.39"	
 s45b (x48) 45 mm / 1.77"	 scn8 (x13)	

**Packaging may contain some additional small parts for use as spare parts | L'emballage peut contenir de petites pièces supplémentaires à utiliser comme pièces de rechange | El envoltorio puede contener algunas piezas pequeñas adicionales que se pueden utilizar como repuestos | In der Verpackung können kleine Zusatzteile enthalten sein, die als Ersatzteile genutzt werden können | De verpakking kan een aantal kleine extra onderdelen bevatten, die als reserveonderdeel gebruikt kunnen worden | La confezione potrebbe contenere piccole parti supplementari da utilizzare come parti di ricambio | A csomagolás tartalmazhat még néhány apró alkatrészt, amelyek pótalkatrészként használhatók**

**NOTE:** Due to variations in production, the actual assembled size may vary slightly from the specified dimensions.

**REMARQUE:** En raison de variantes dans la production, la taille de montage réelle peut différer quelque peu des dimensions indiquées.

**NOTA:** debido a las variaciones en la producción, el tamaño real al montarlo puede variar ligeramente con respecto a las dimensiones especificadas.

**BITTE BEACHTEN:** Auf grund von Abweichungen in der Herstellung kann die tatsächliche Größe leicht von den angegebenen Maßen abweichen.

**LET OP:** vanwege afwijkingen in de productie kan de werkelijke afmeting na montage een klein beetje afwijken van de opgegeven afmetingen

**NOTA:** a causa di variazioni nella produzione, la dimensione effettiva del prodotto assemblato può variare leggermente dalle dimensioni menzionate.

**MEGJEGYZÉS:** A gyártási különbségek miatt a szerelvény tényleges mérete kissé eltérhet a megadott mérettől.

1

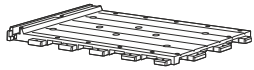

MOFF9 (x2)

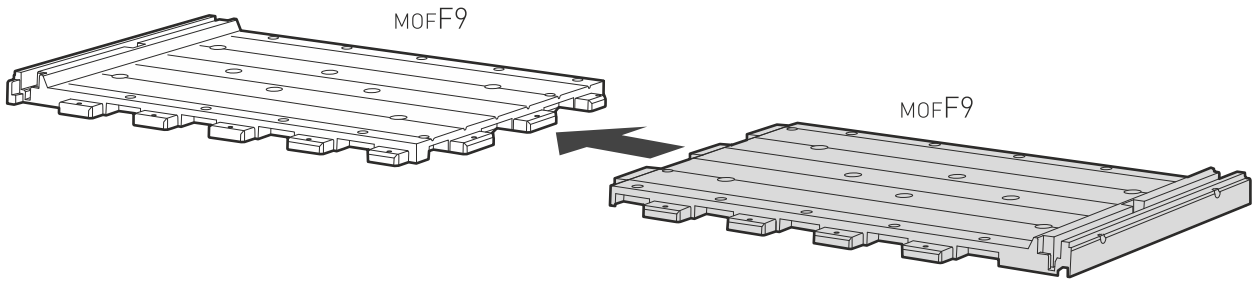
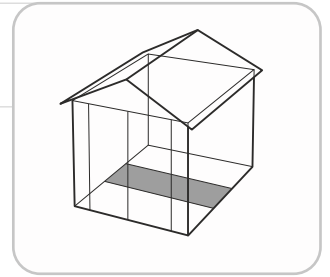

2



sc15 (x4)

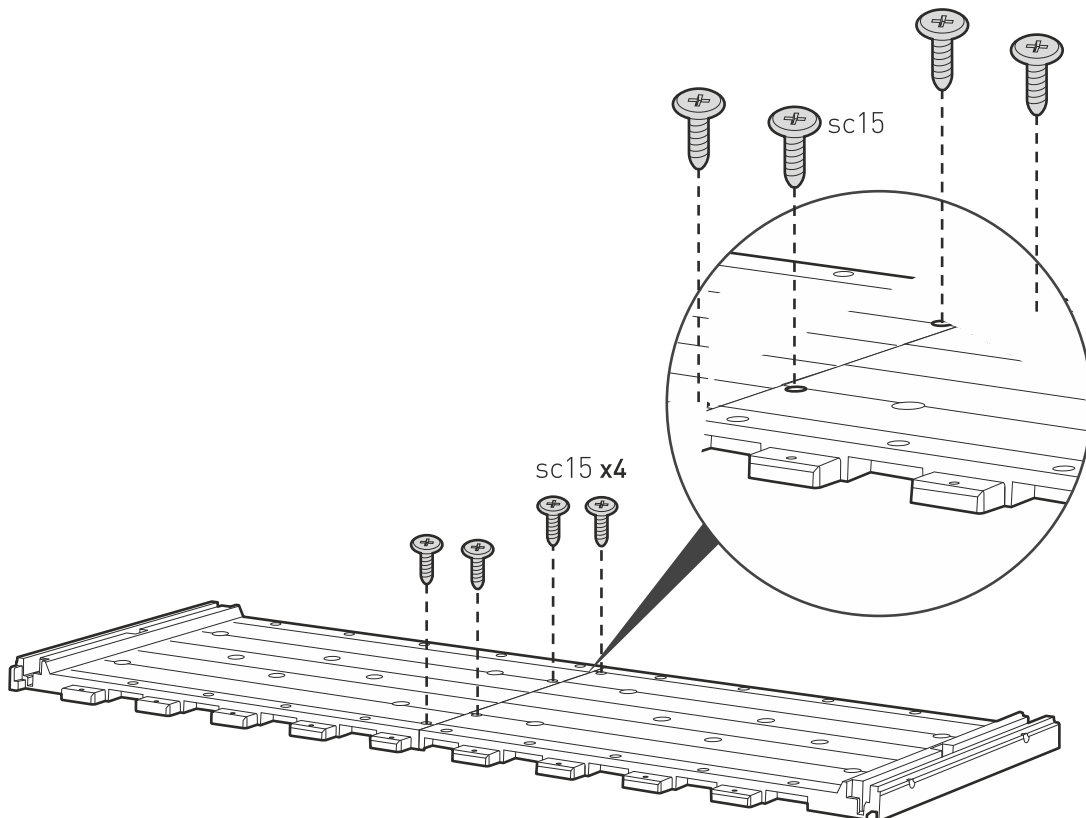
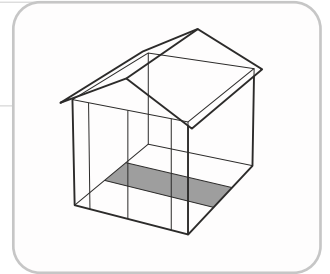

3

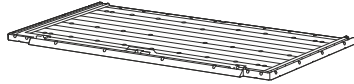
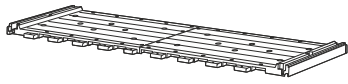

MOFFL (x2)

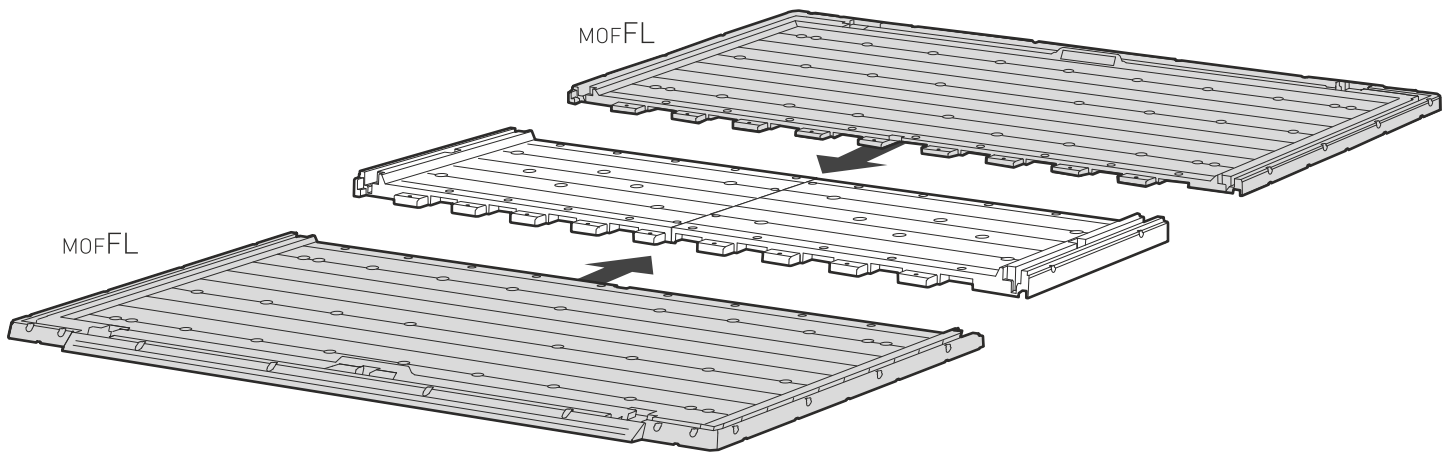
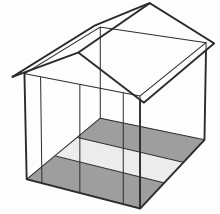

4



sc15 (x36)

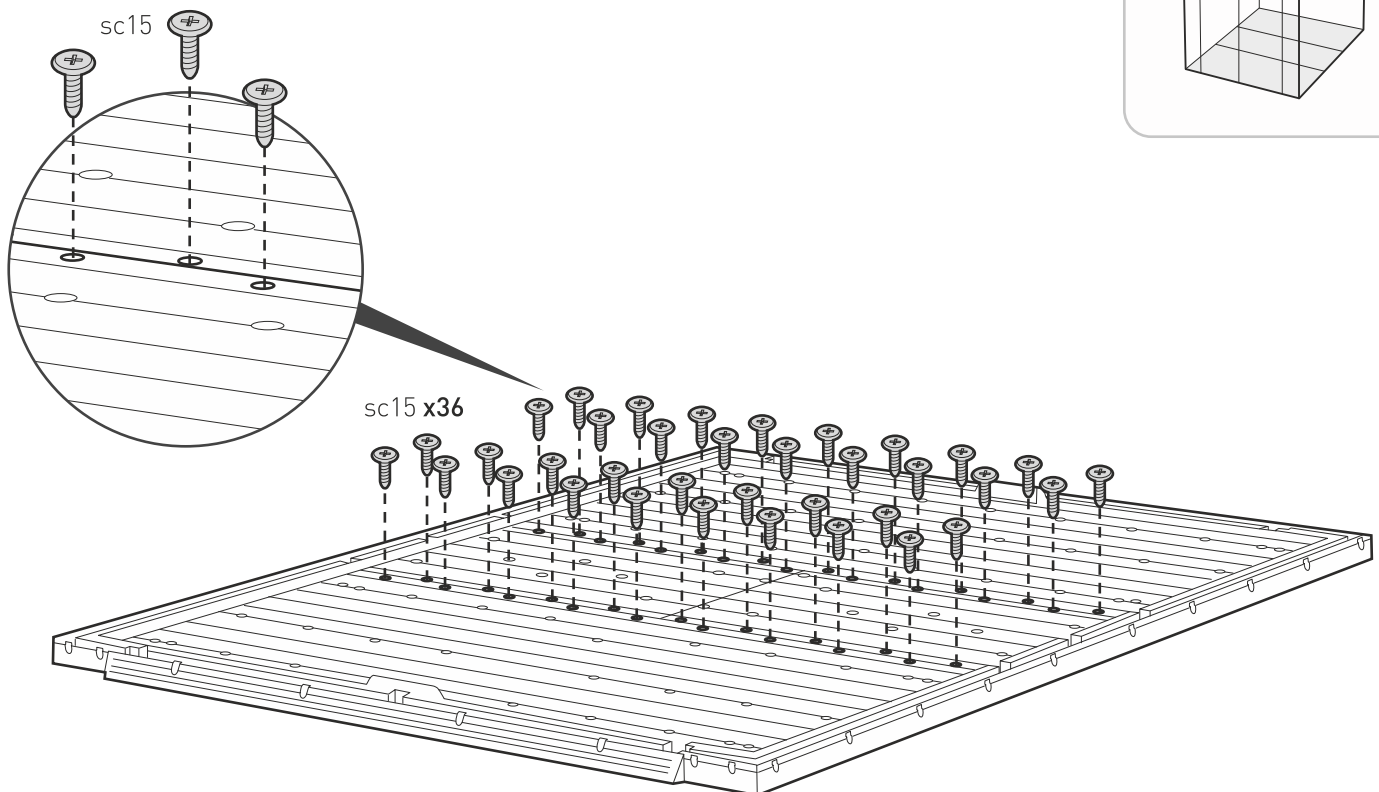
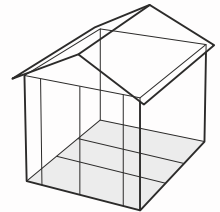



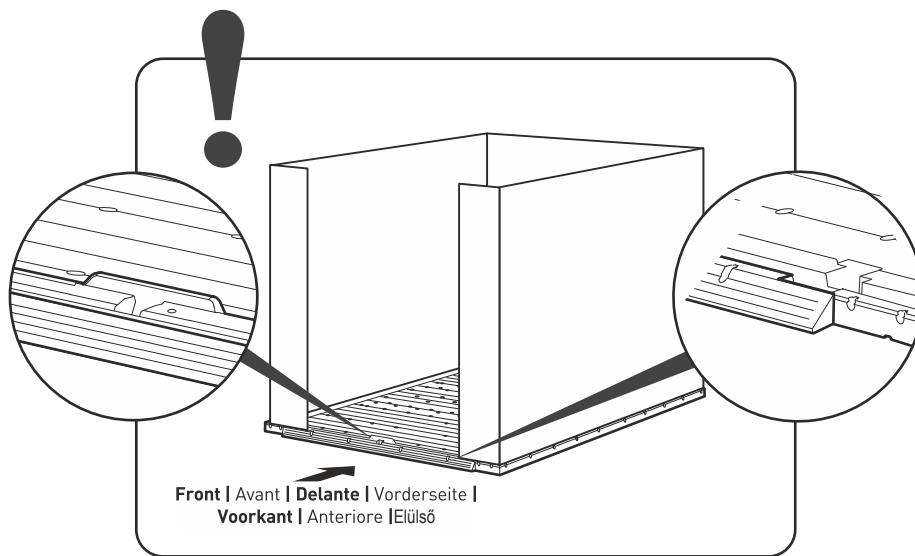

5



NE-DT (x1)



s26b (x2)

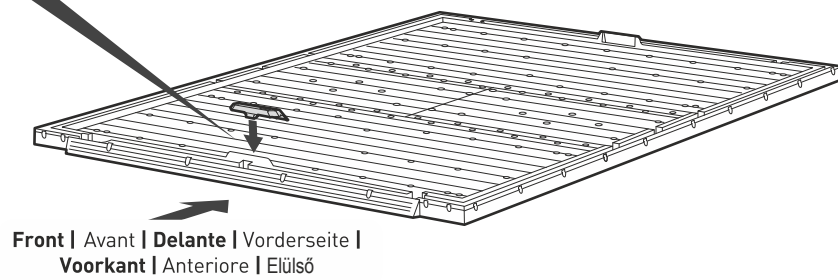
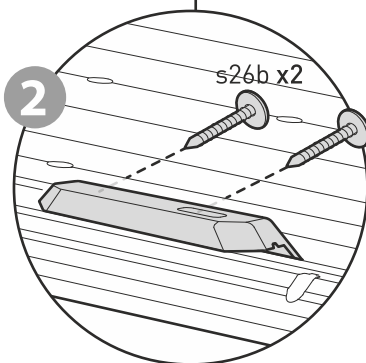
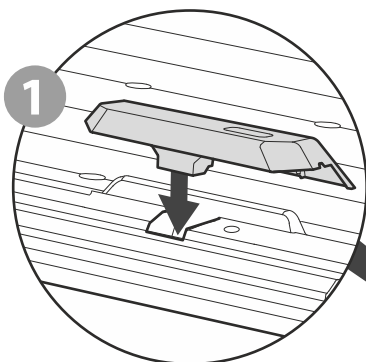
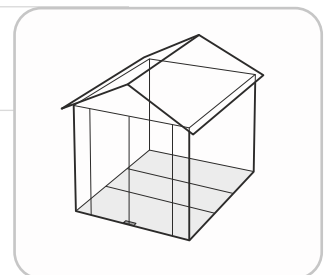

WALL ASSEMBLY | MONTAGE DU MUR | MONTAJE DE LAS PAREDES | MONTAGE DER WÄNDE | MONTAGE VAN DE MUREN | ASSEMBLAGGIO DELLE PARETI | FALRA SZERELÉS

6

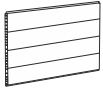

ncPB9 (x2)



ncPB7 (x1)

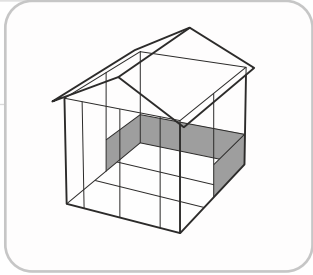

**Outside**  
 Extérieure  
**Exterior**  
 Außenseite  
**Büitenkant**  
 Esterno  
 Szabadtéri

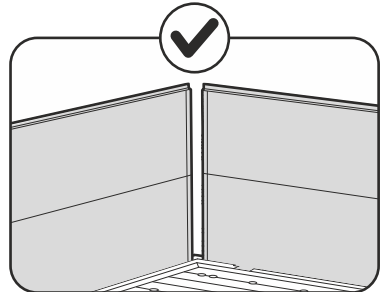
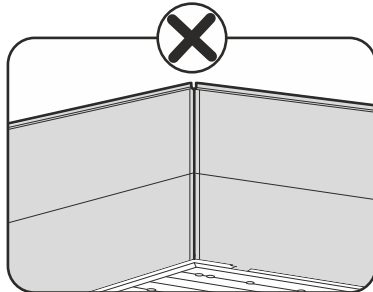

**! Front** | Avant | Delante | Vorderseite |  
**Voorkant** | Anteriore | Elülső

7

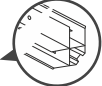
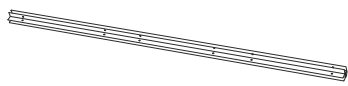

NECA (x2)

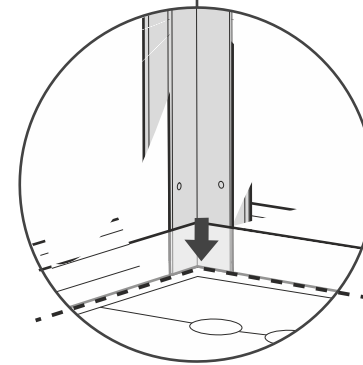
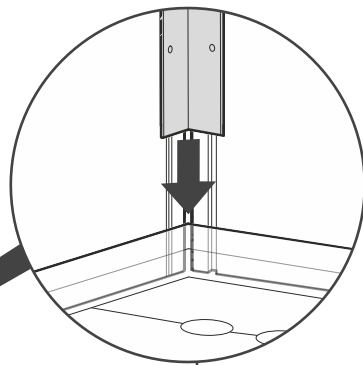
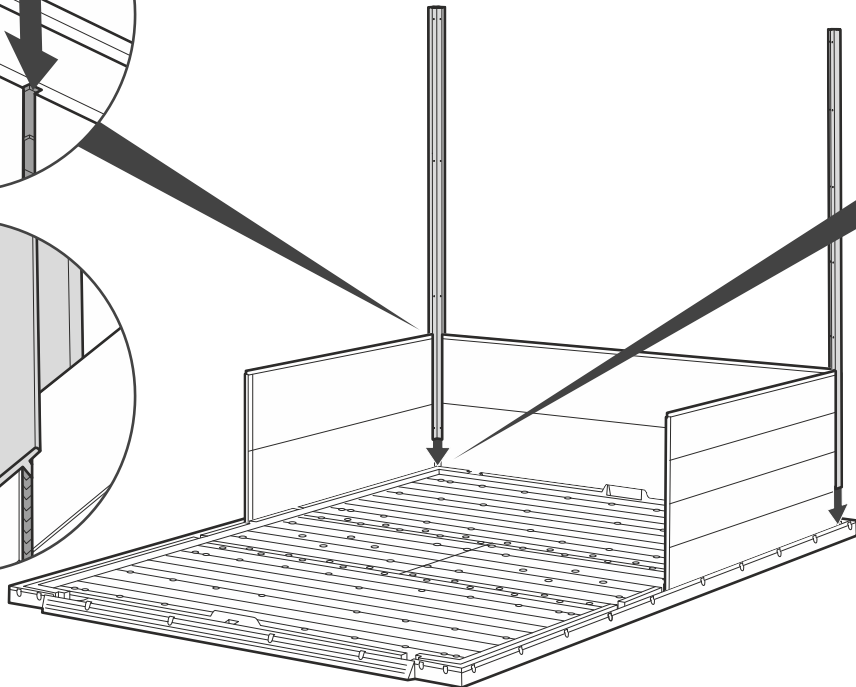
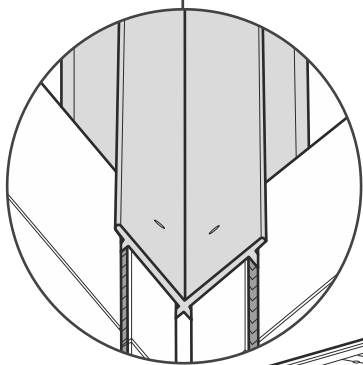
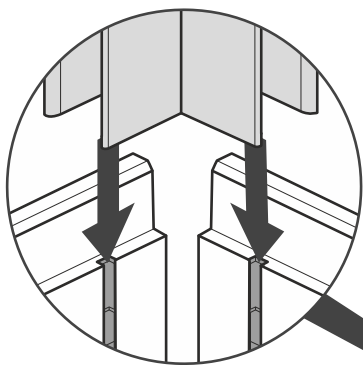
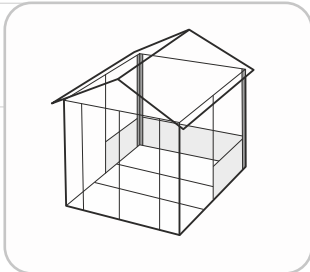

8



s13b (x4)

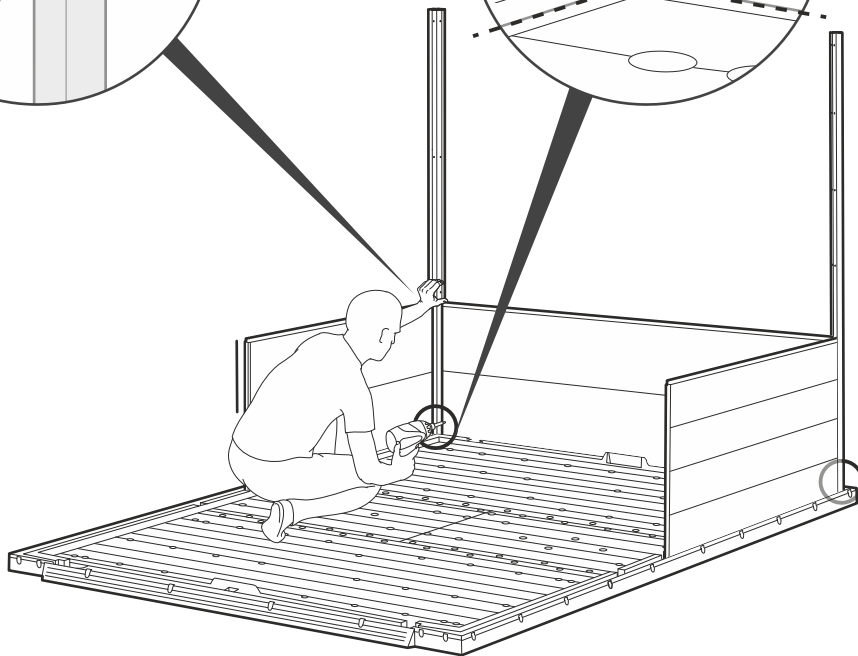
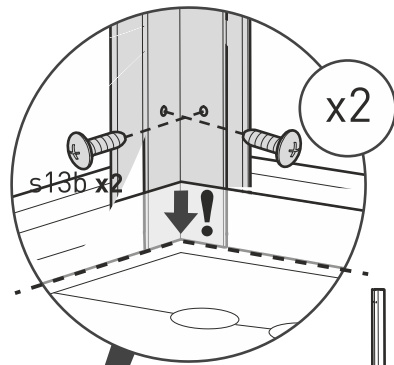
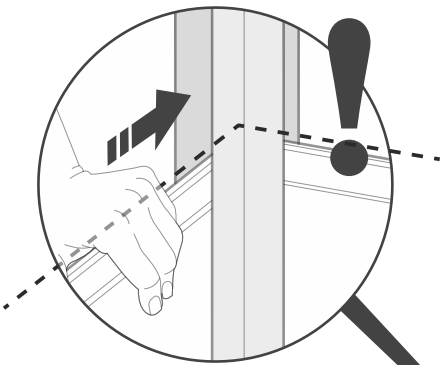
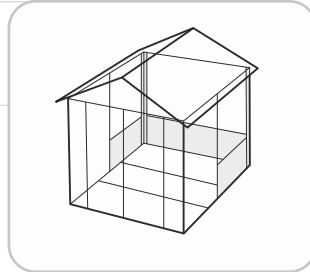

9

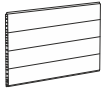

ncPB9 (x2)

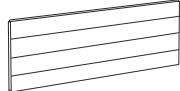

ncPB7 (x1)

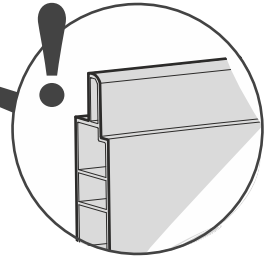
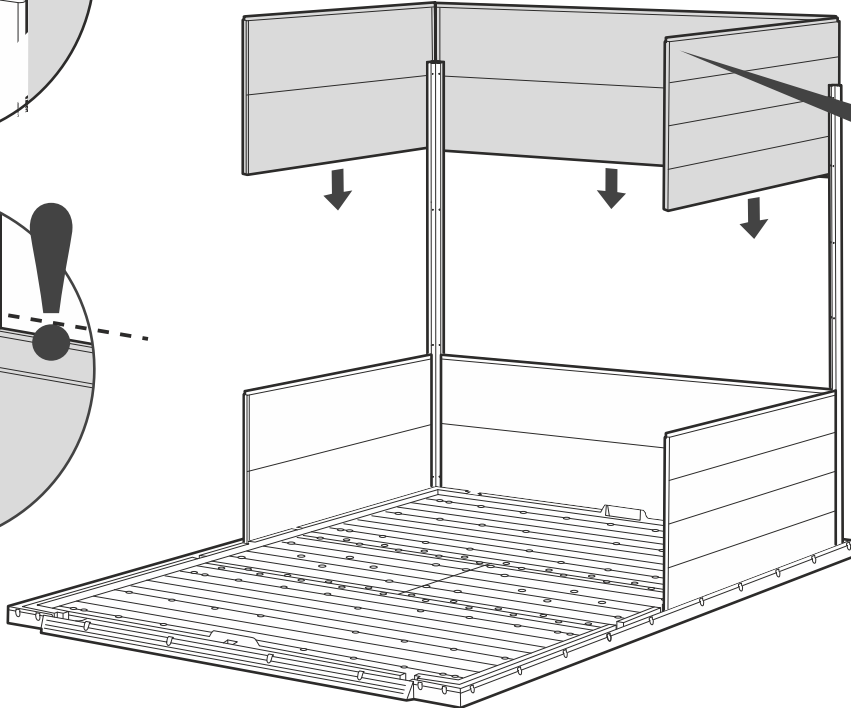
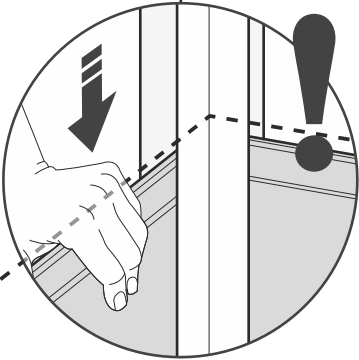
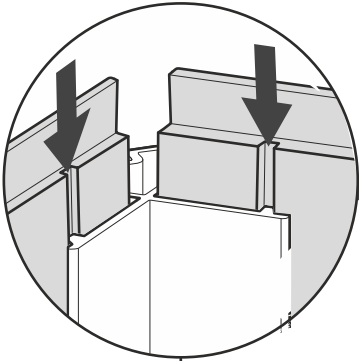
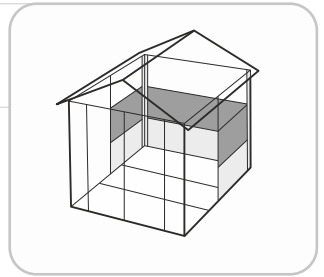

10



s13b (x4)

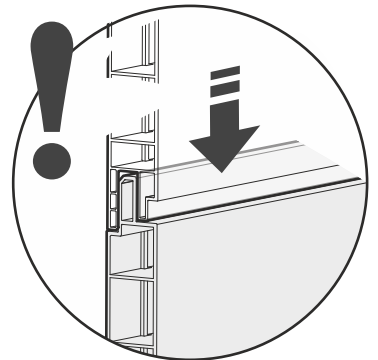
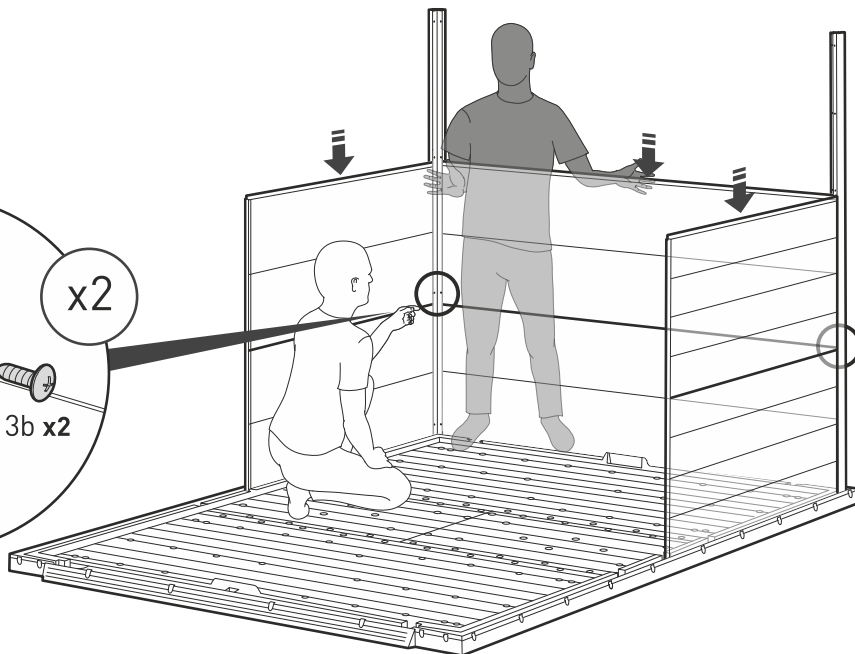
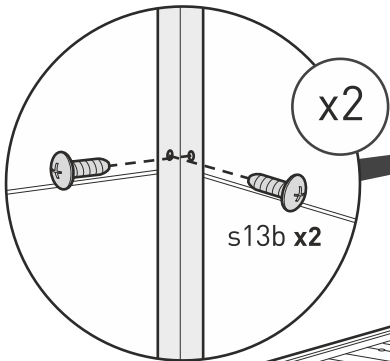
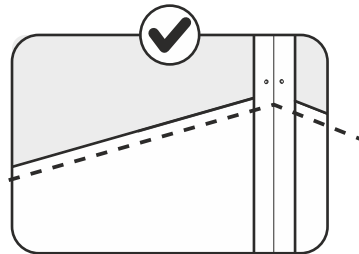
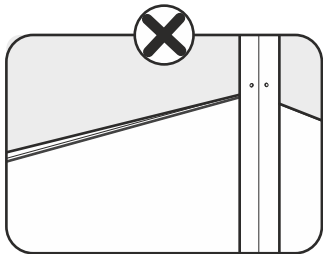
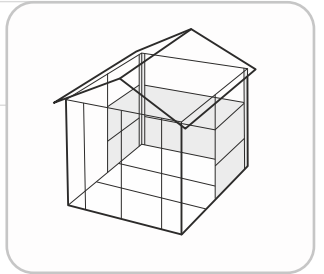

11

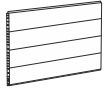

ncPB9 (x2)



ncPB7 (x1)

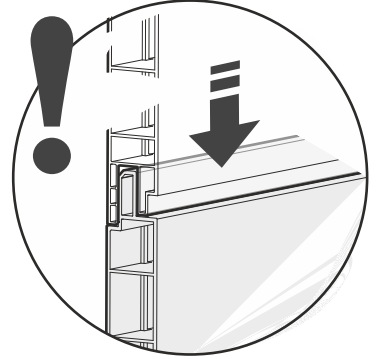
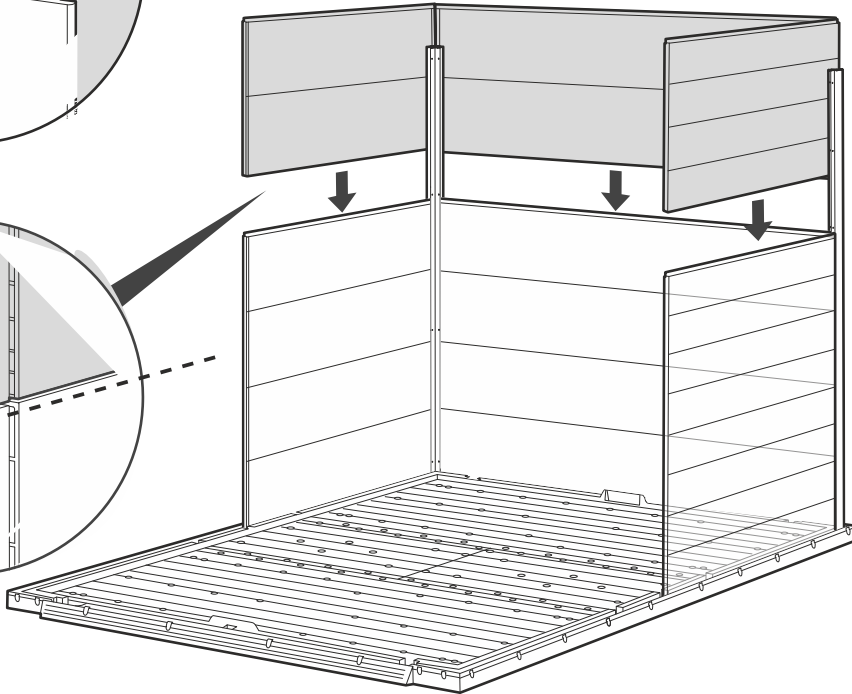
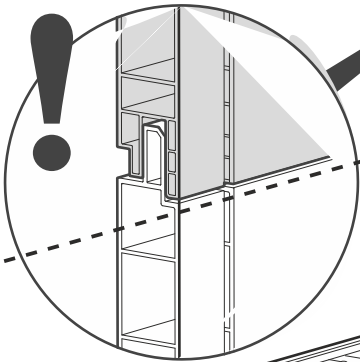
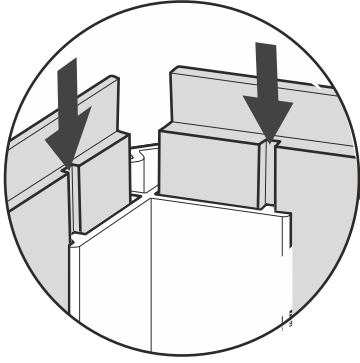
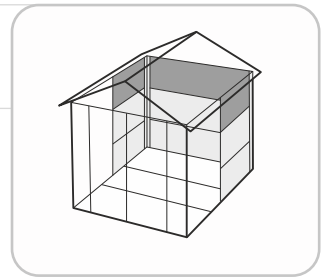

12

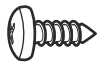

s13b (x8)

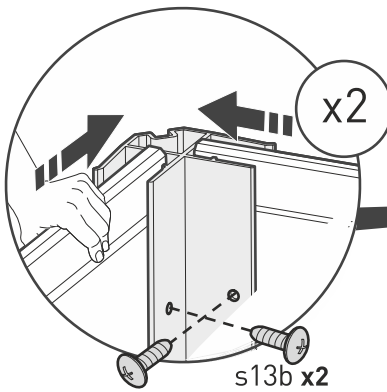
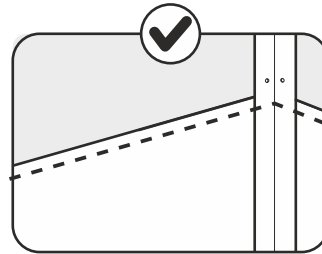
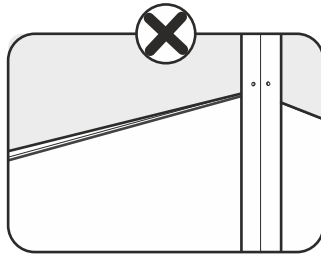
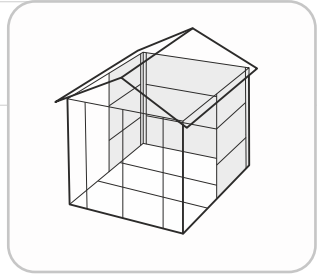

s13b x2

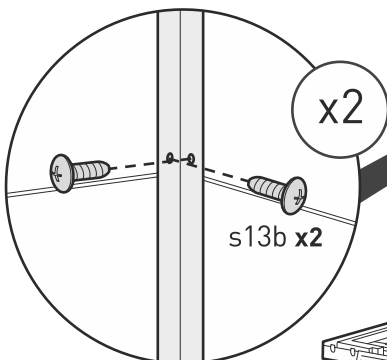

s13b x2

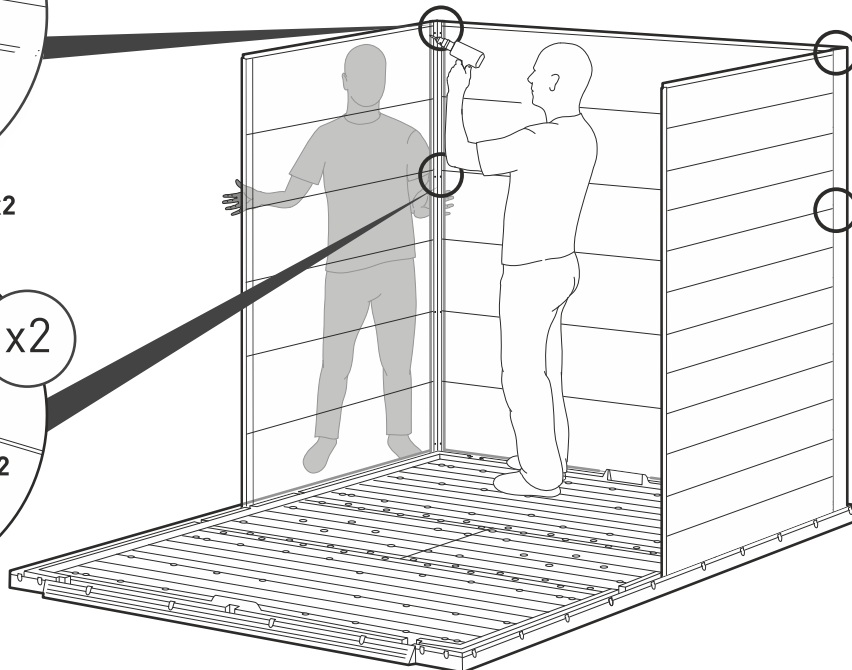

13



NECS (x1)

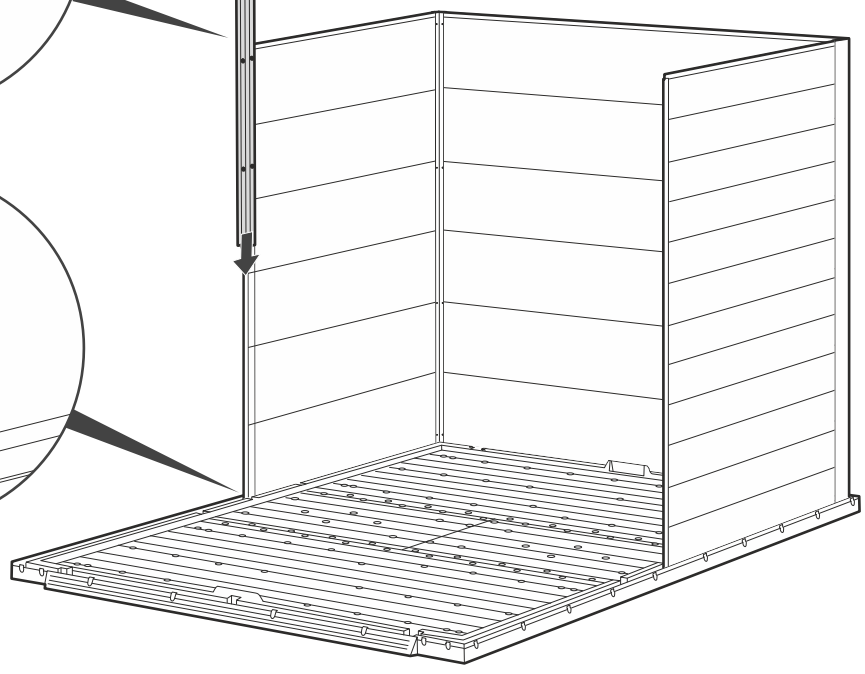
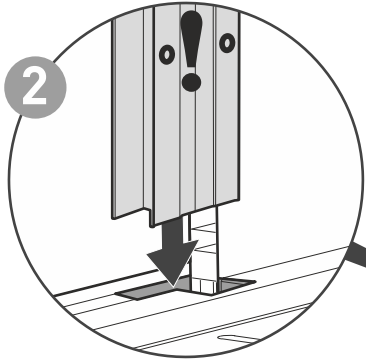
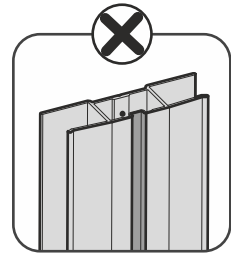
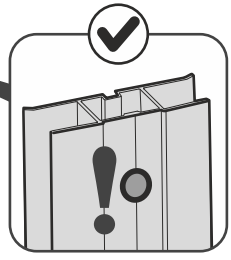
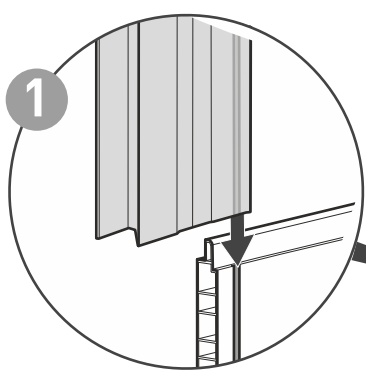
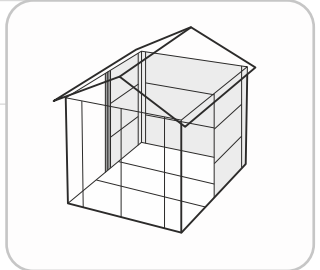

14

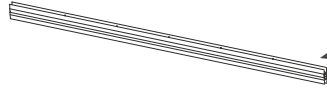

NECS (x1)

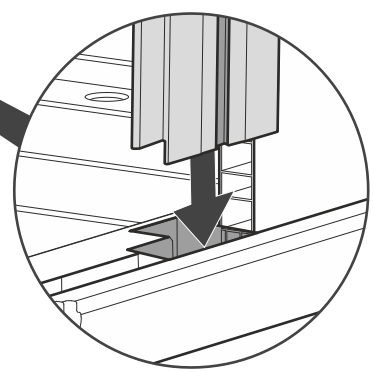
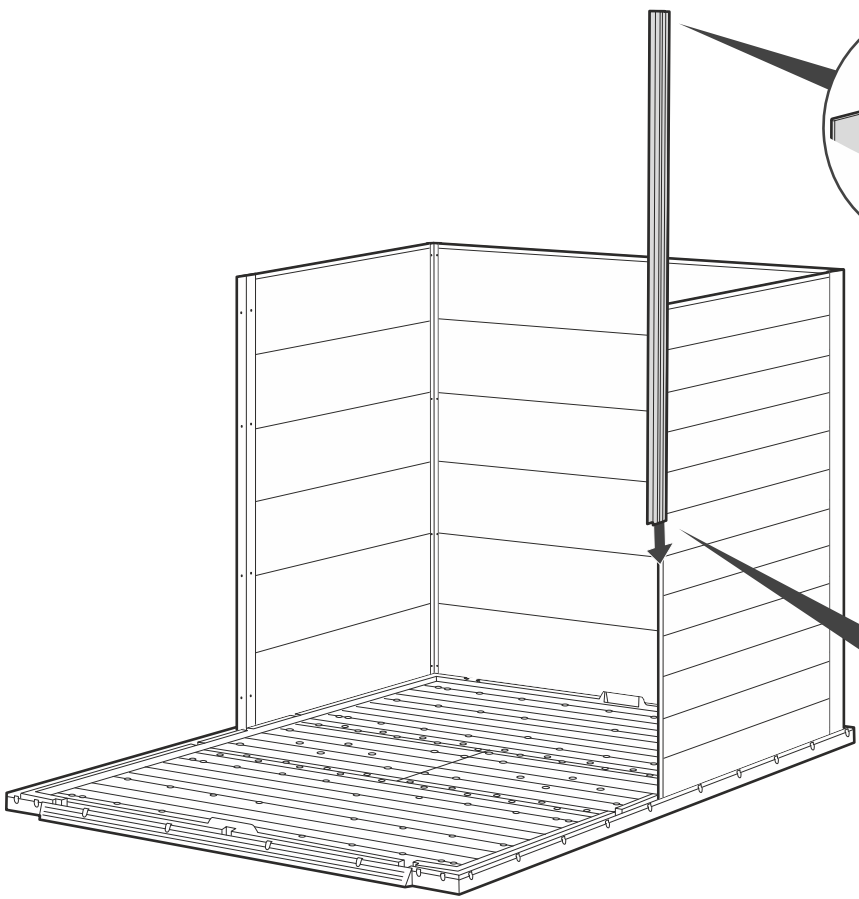
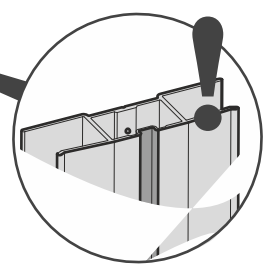
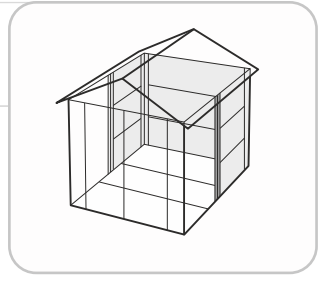

15

s13b (x8)

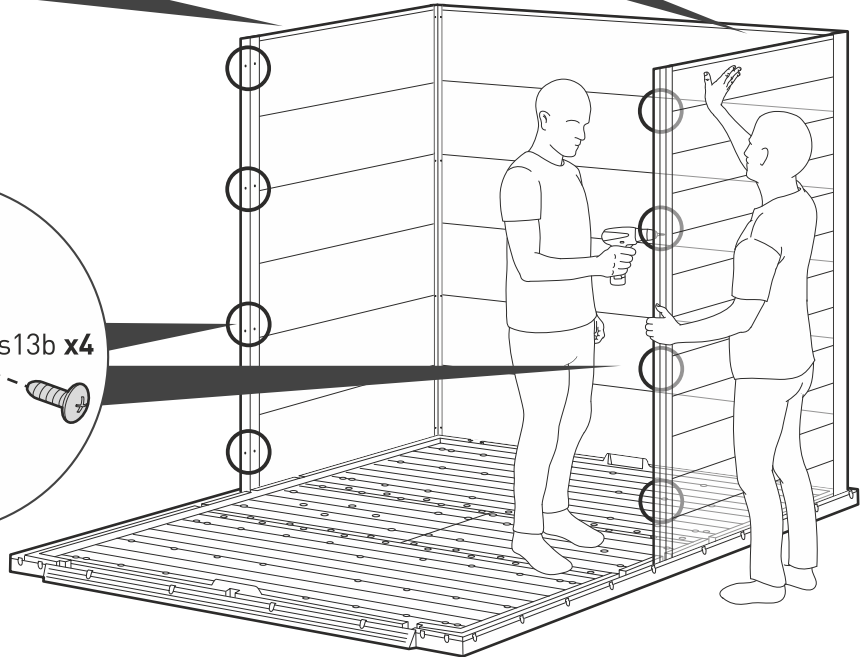
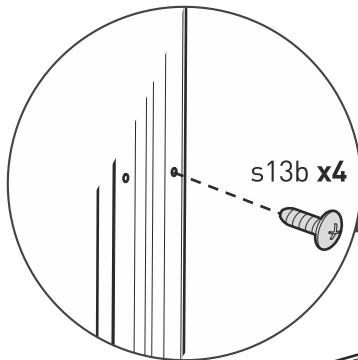
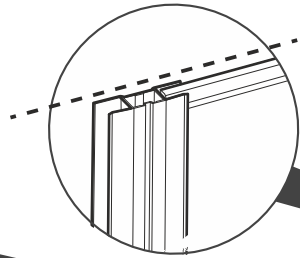
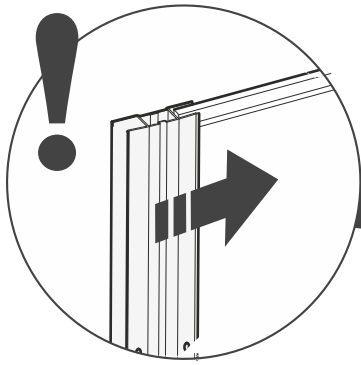
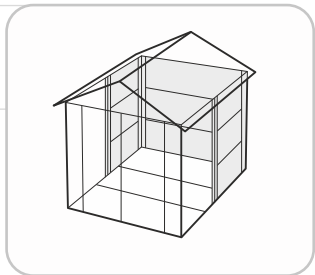

16



NEHSC (x2)

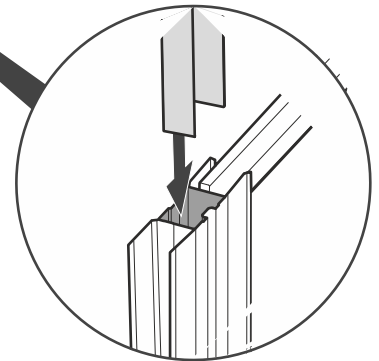
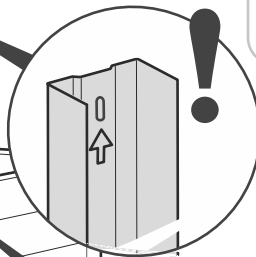
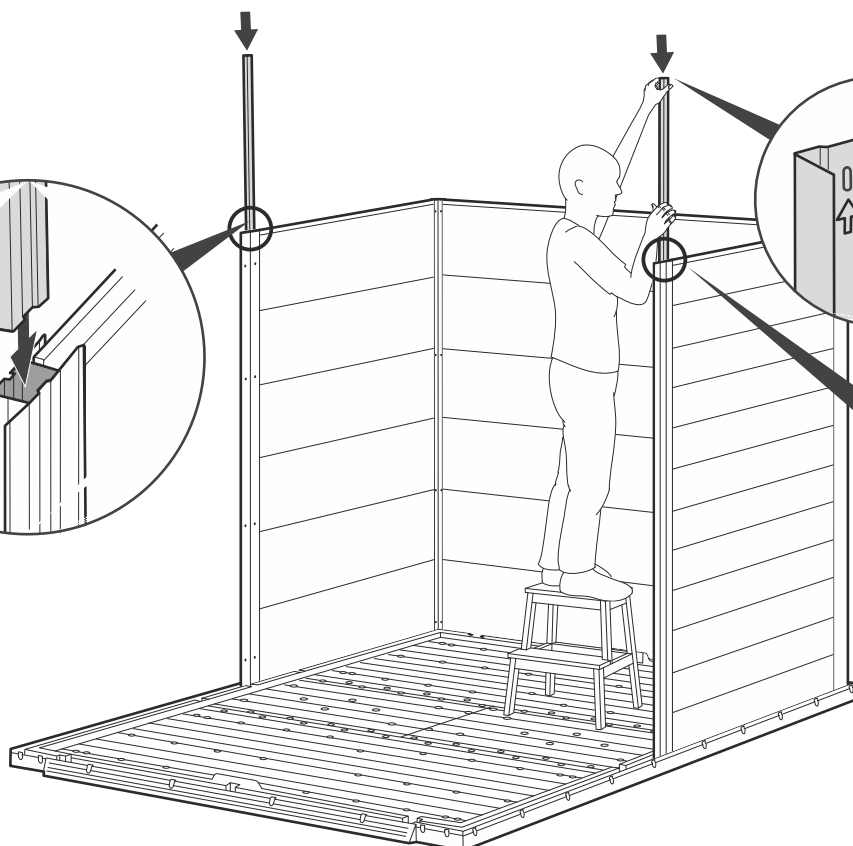
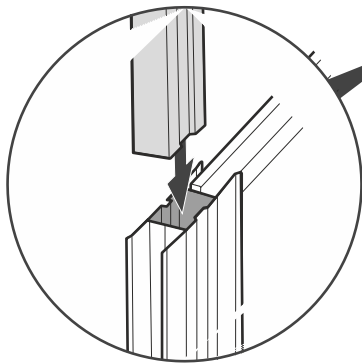
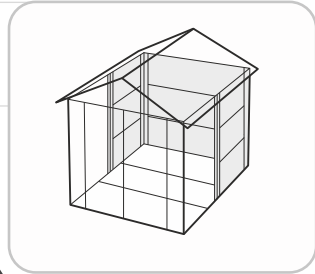

17

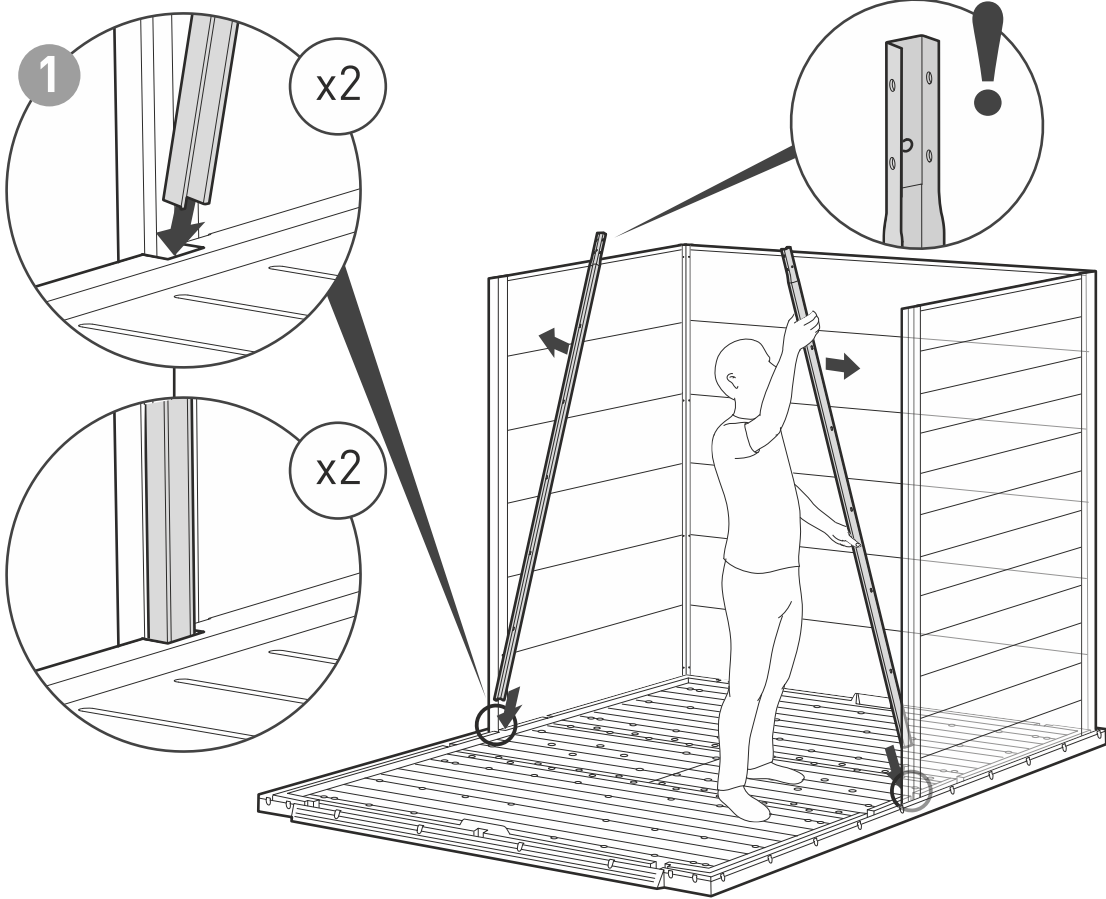
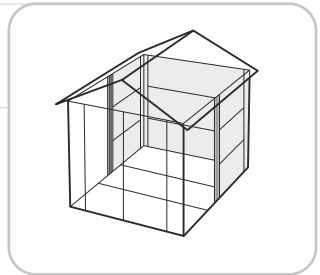

18

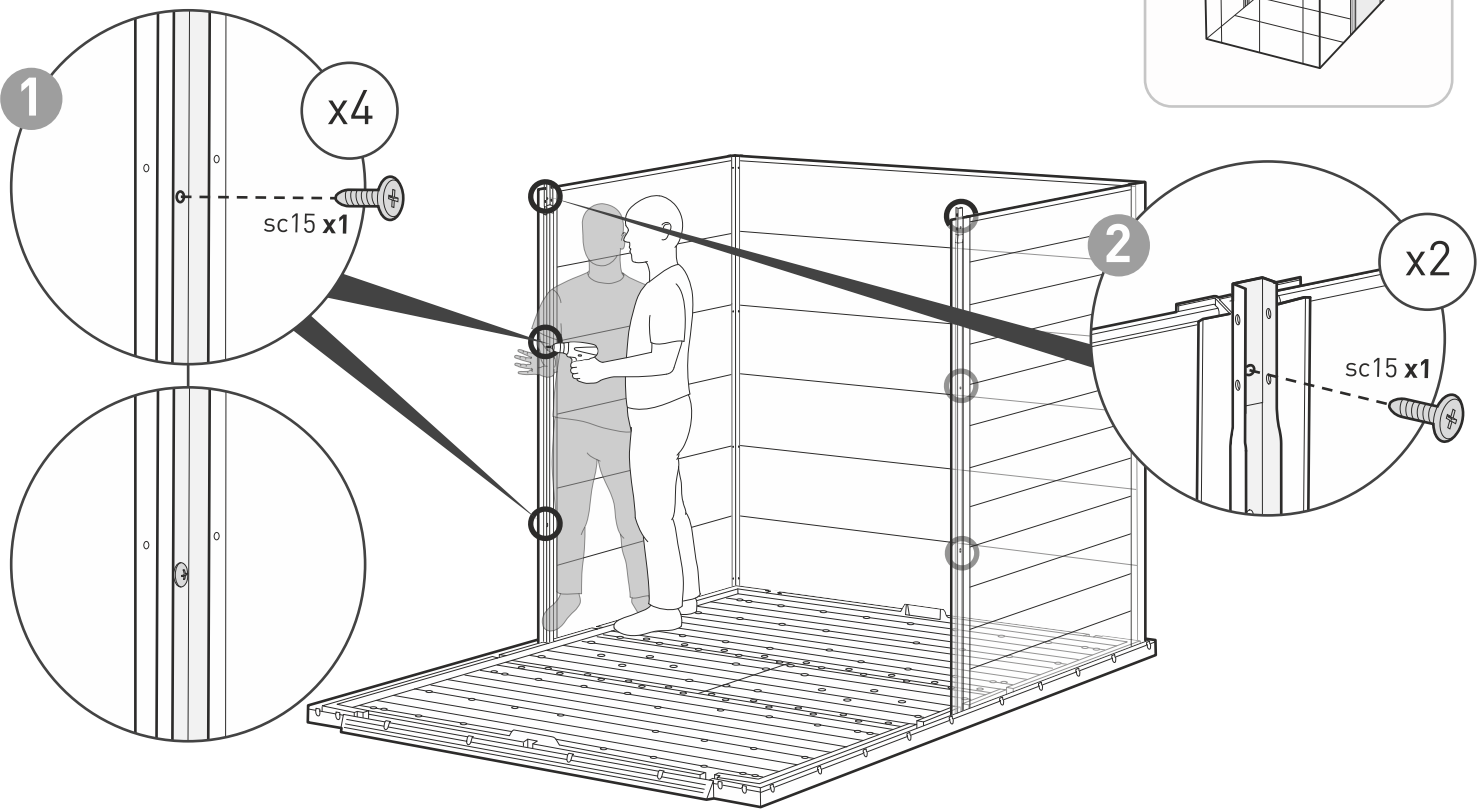
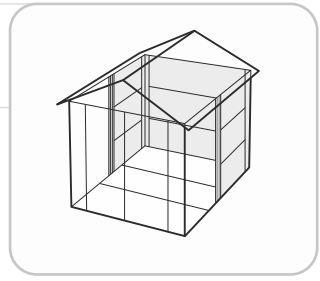



19

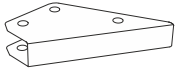

FNME (x2)

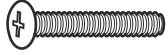

sc8 (x2)



scn8 (x2)

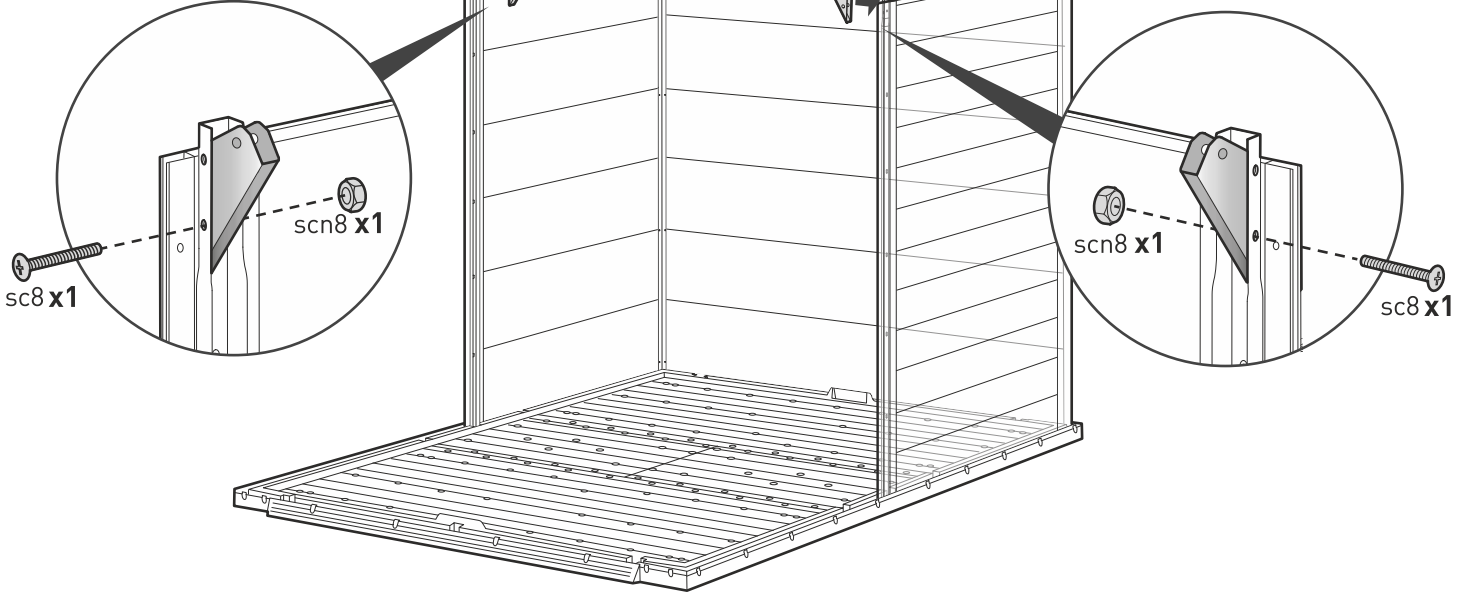
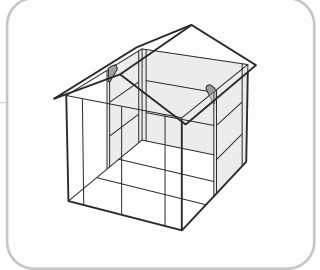

20



m0SF (x2)



FNMH (x1)



FNMA (x1)

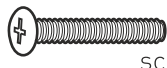

sc8 (x6)



scn8 (x6)

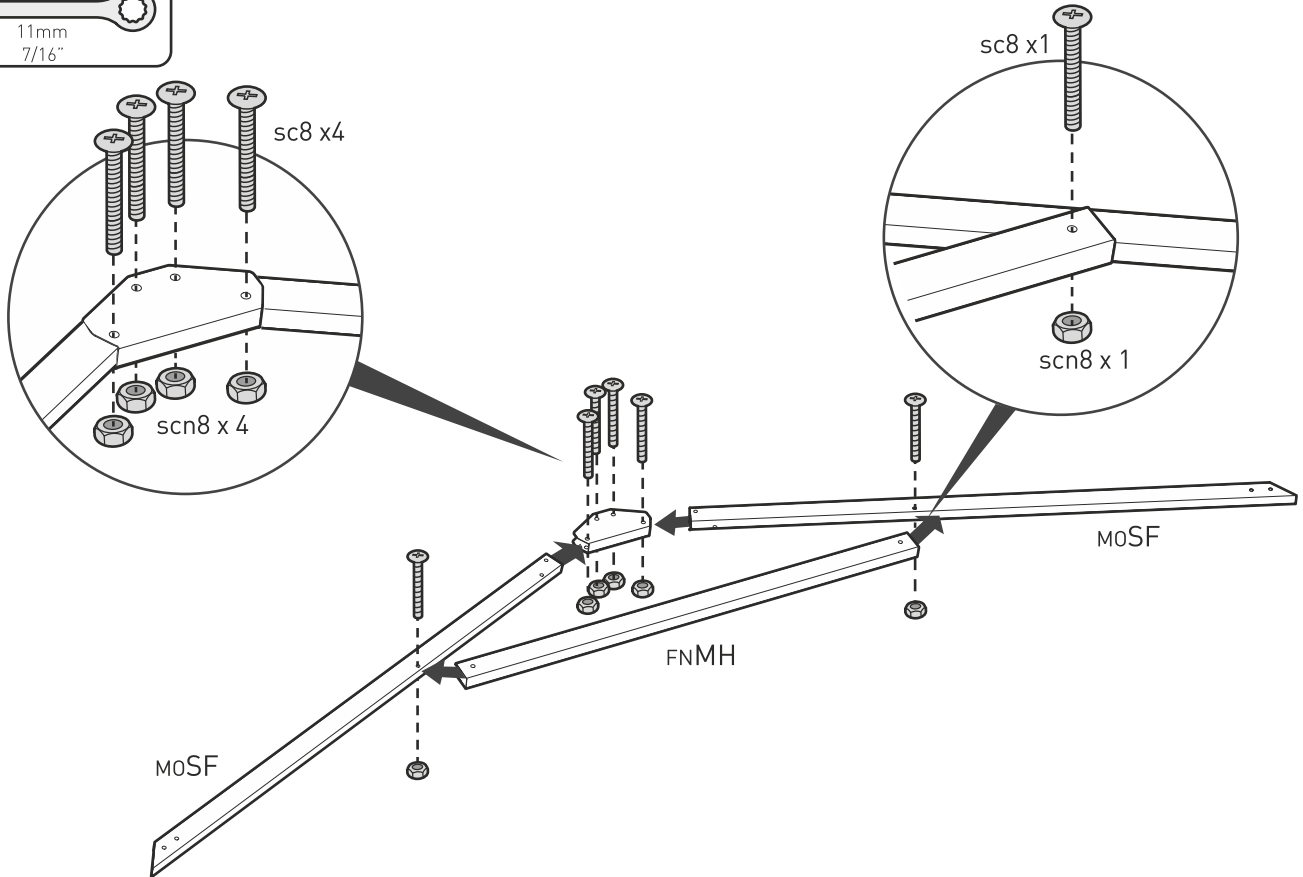

21

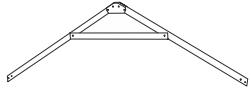

sc8 (x4)

scn8 (x4)

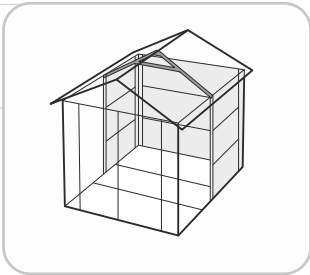

11mm  
7/16"

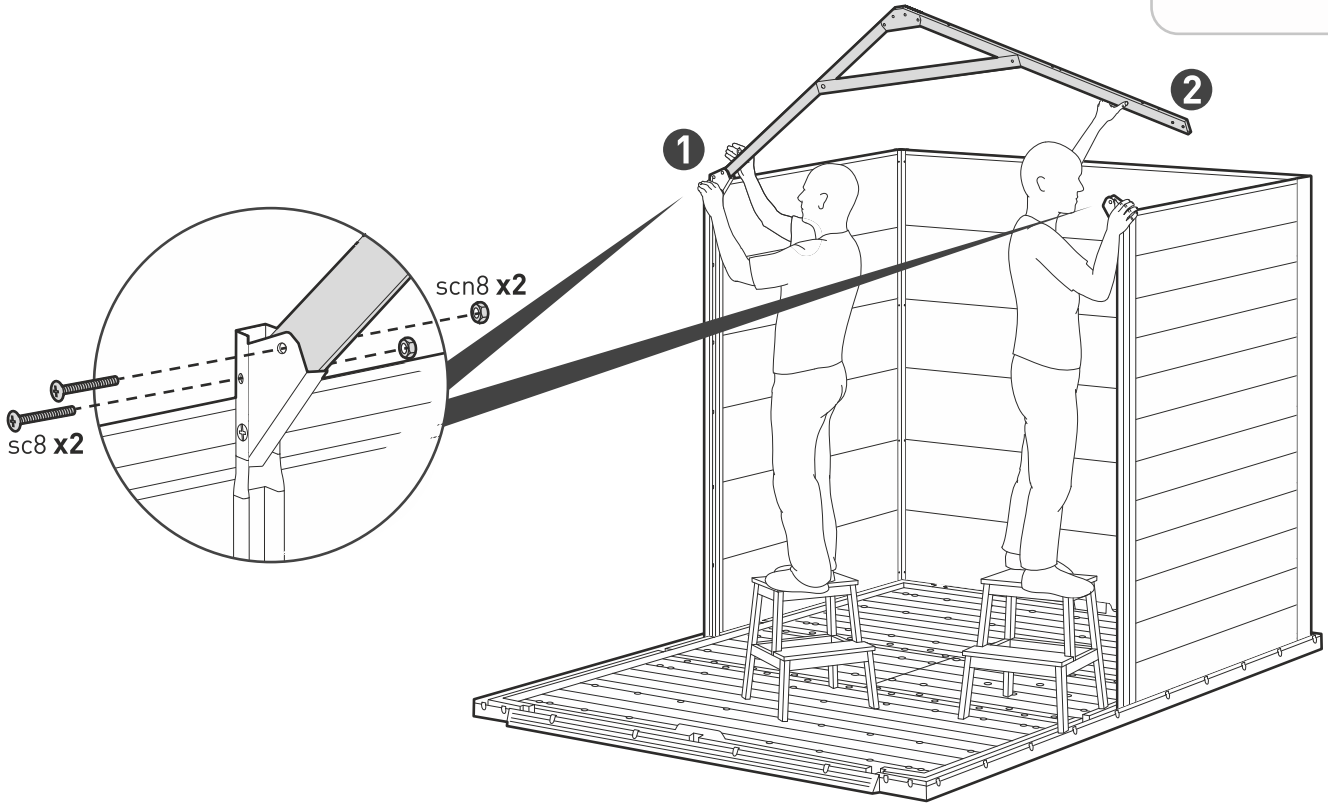

22

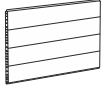

NC PB9 (x2)



NC DF (x2)

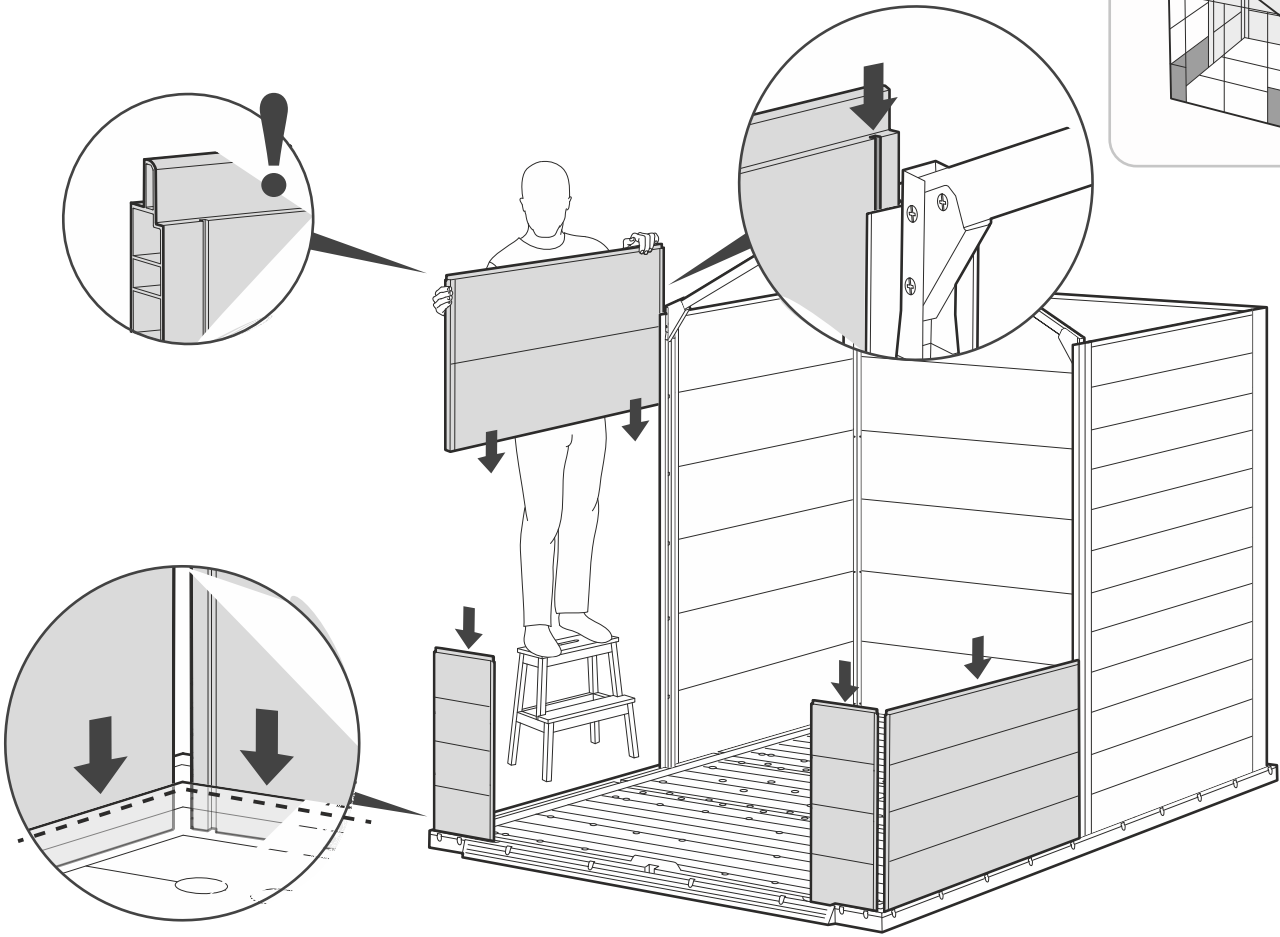
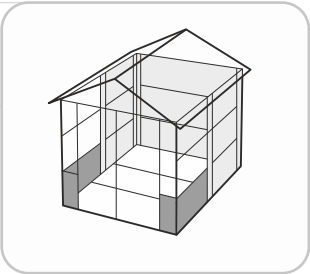

23

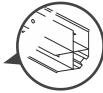
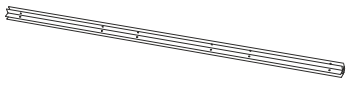

NECA (x2)

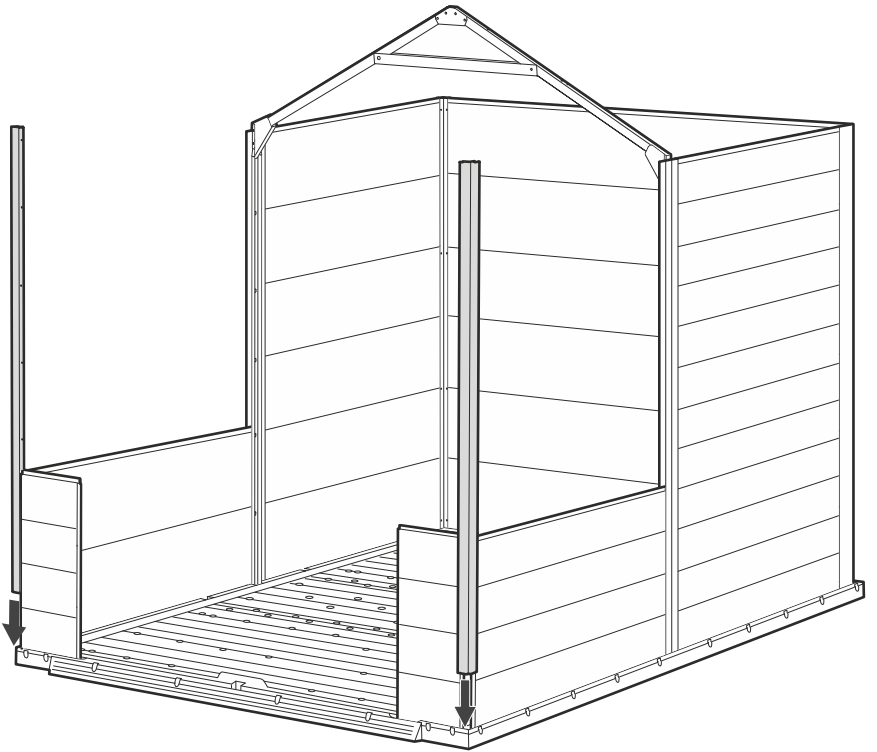
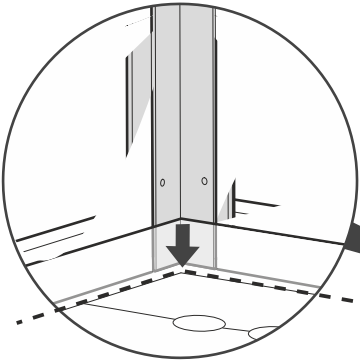
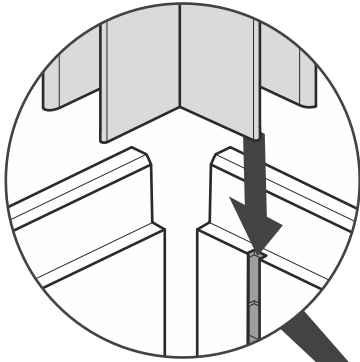
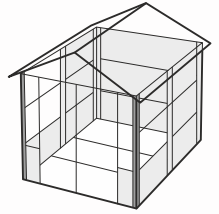

24



S13b (x4)

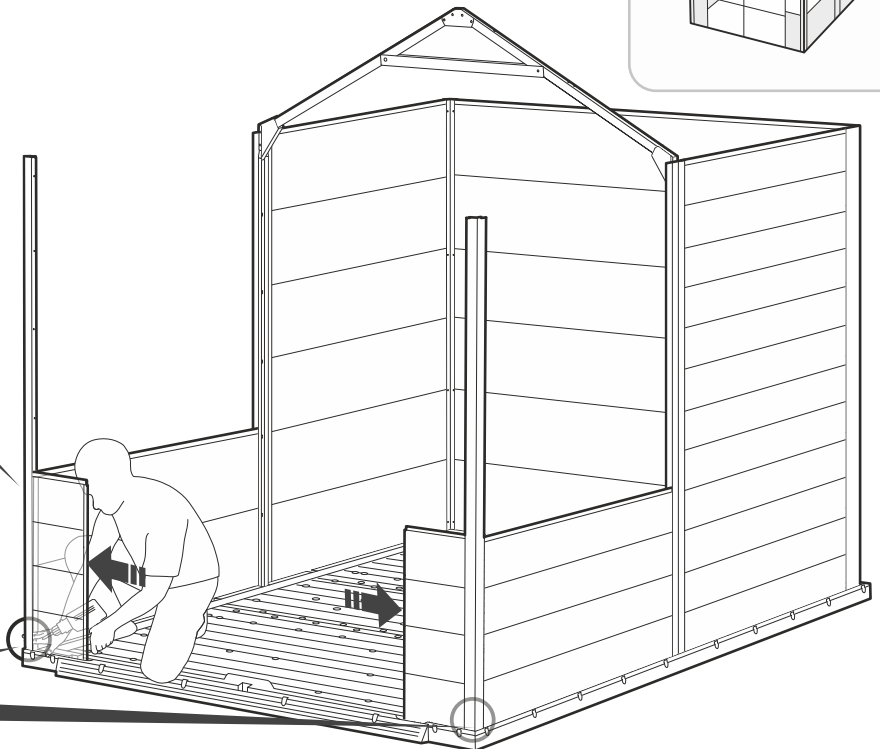
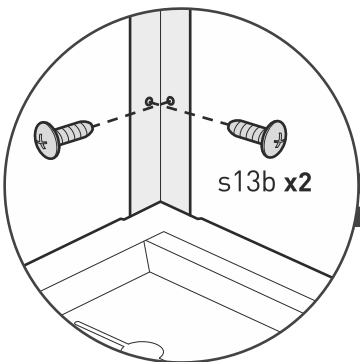
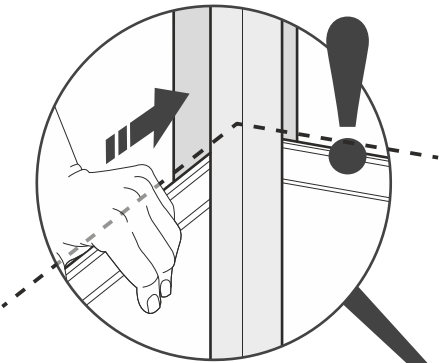
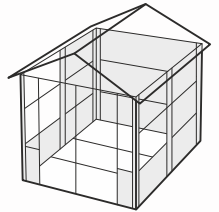

25



S45b (x2)

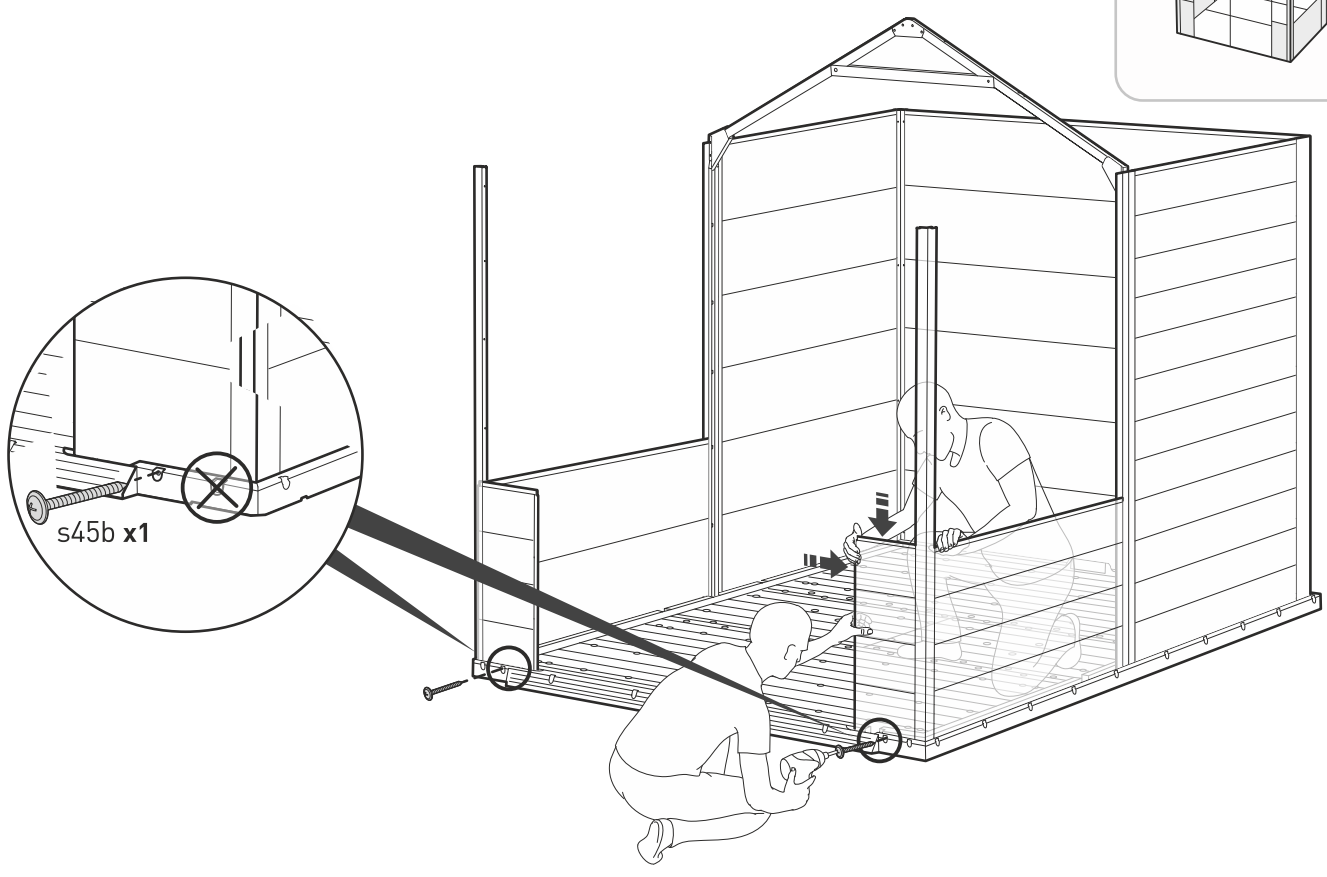
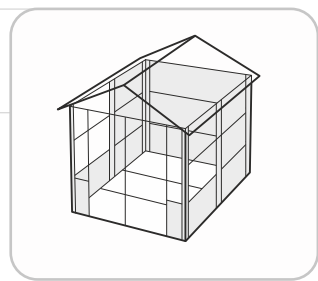

26

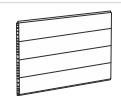

ncPB9 (x2)

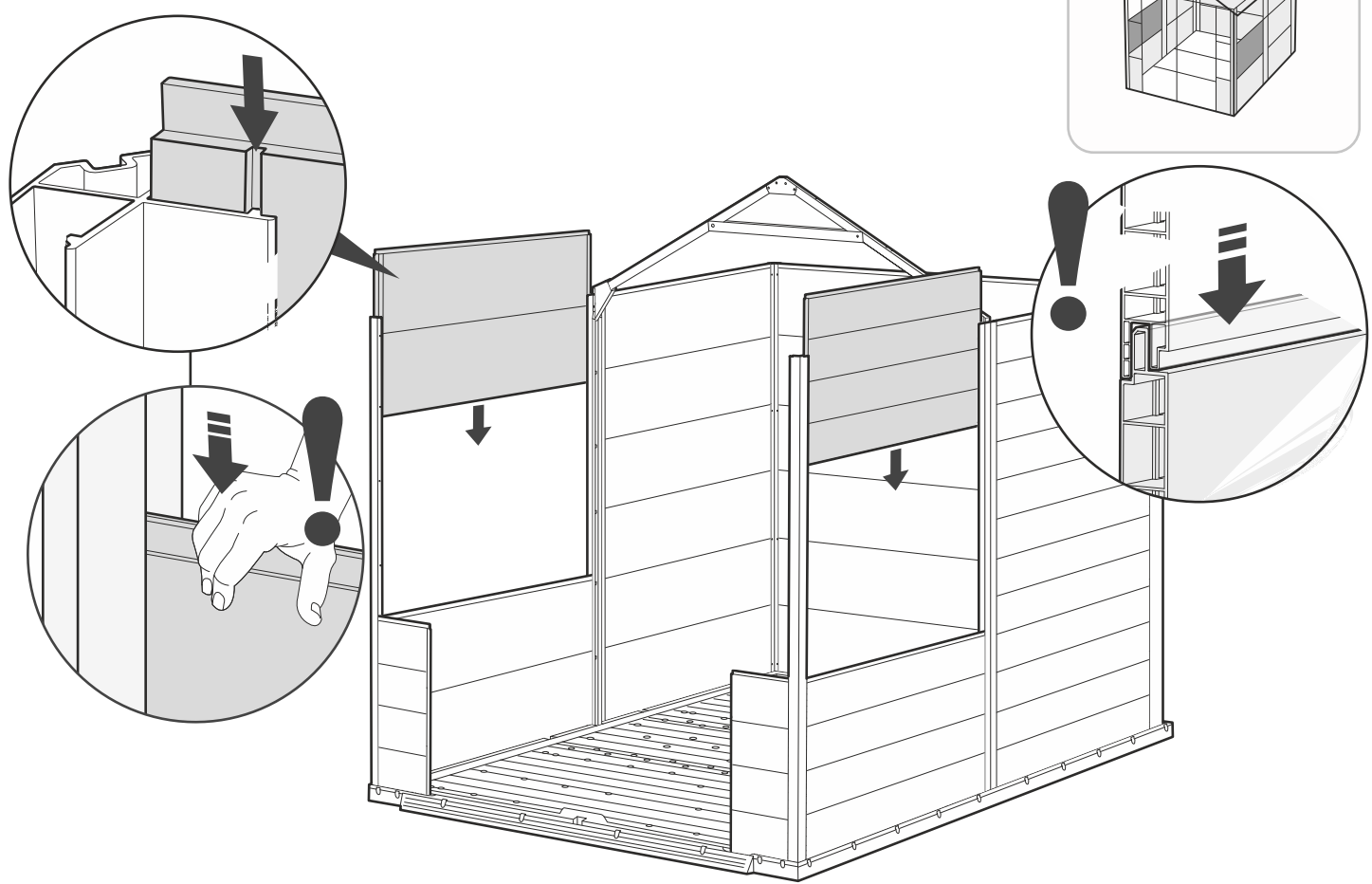
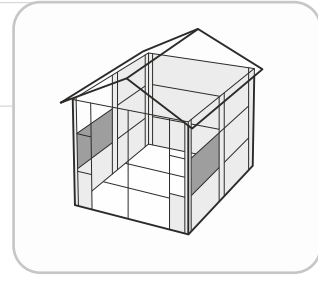

27

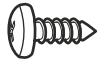
 s13b (x2)

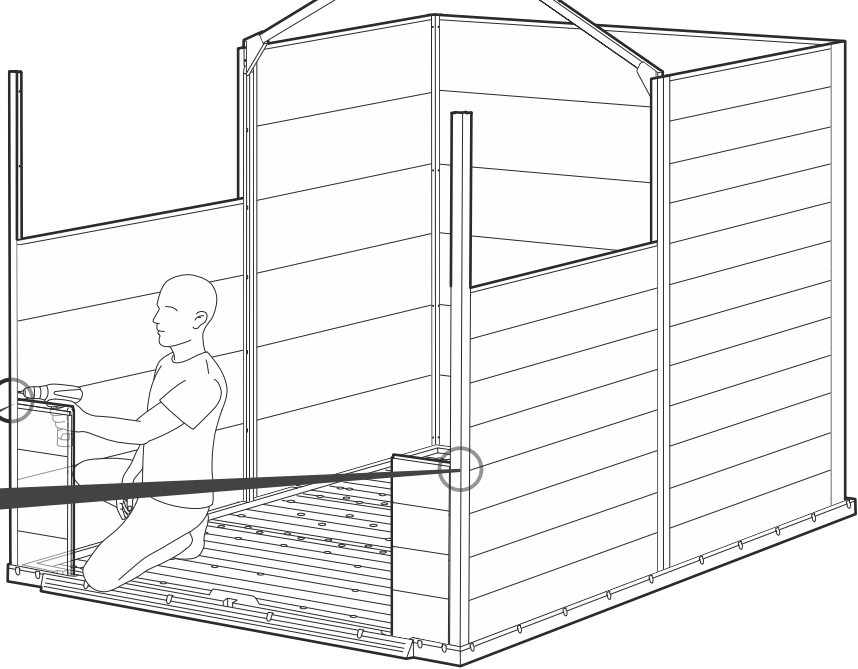
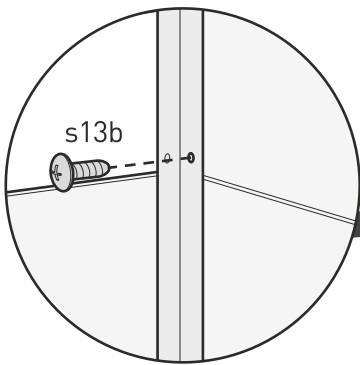
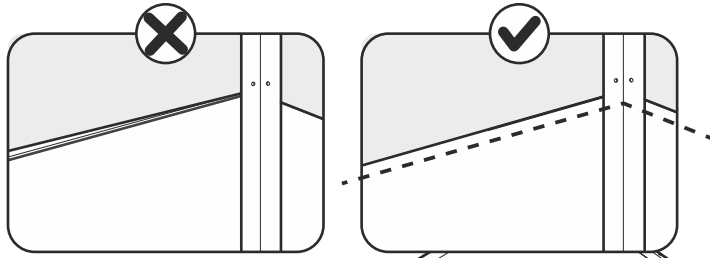
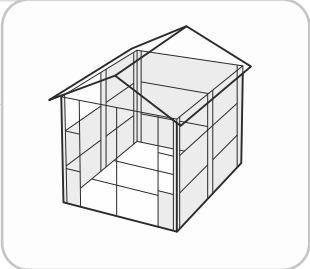

28

 ncPB9 (x2)

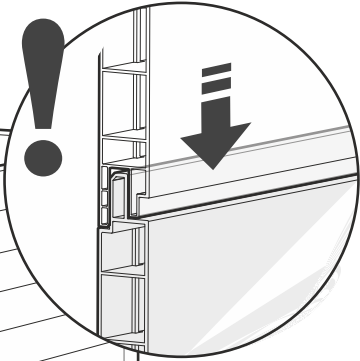
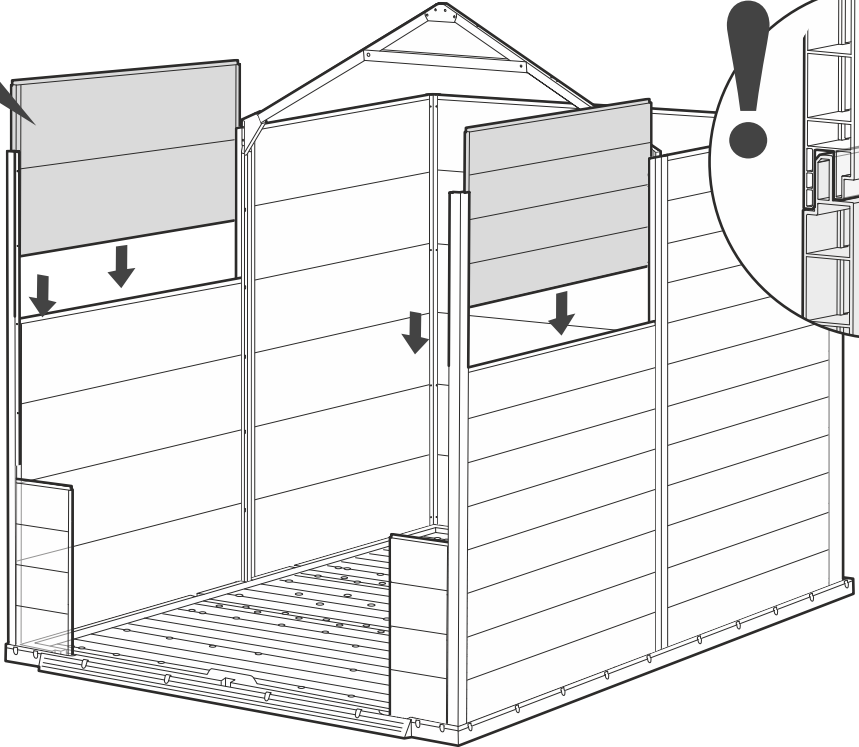
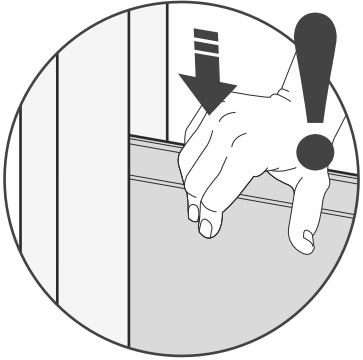
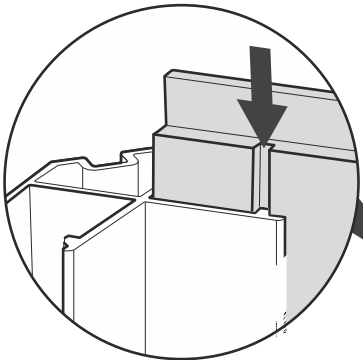
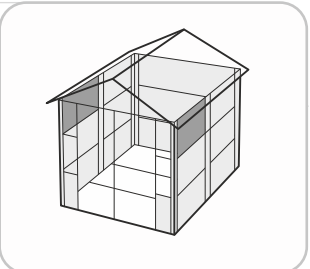

29

s13b (x4)

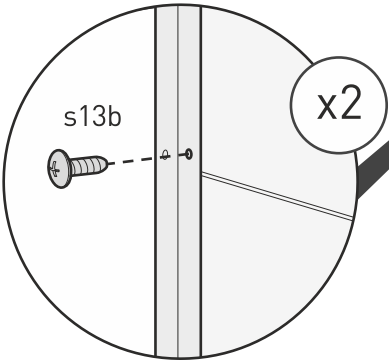
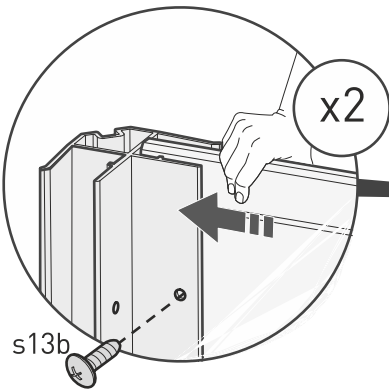
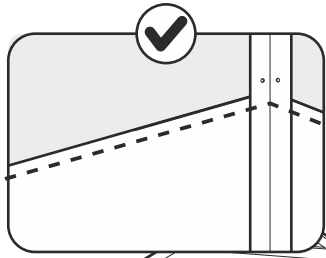
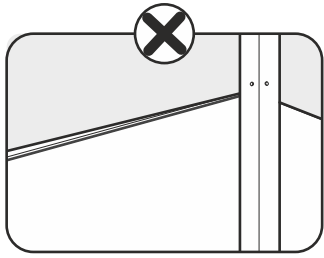
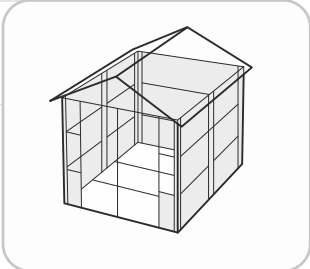

30

ncDF (x4)

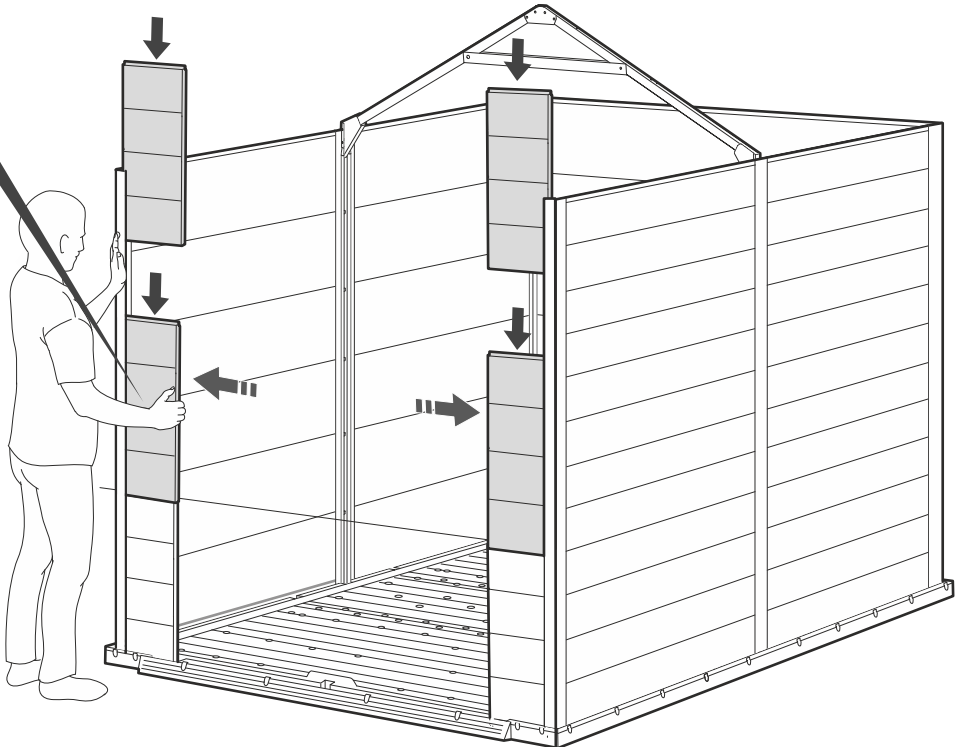
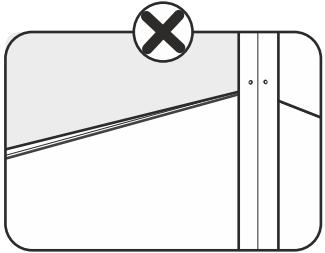
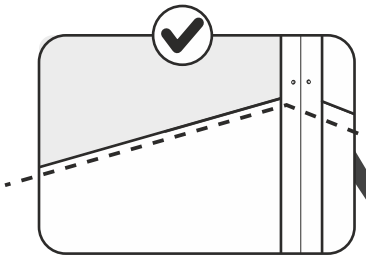
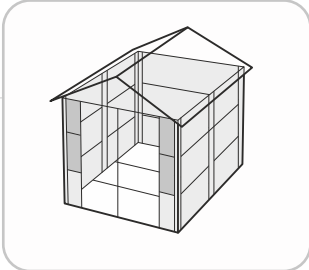

31

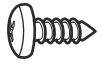

s13b (x4)

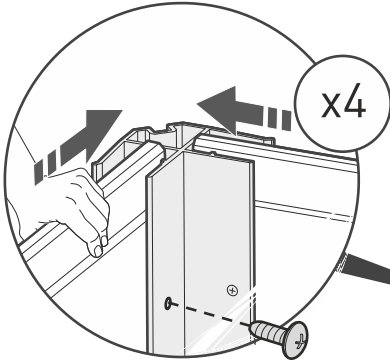
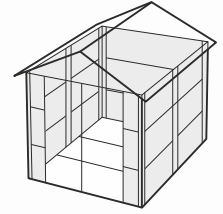

x4

s13b

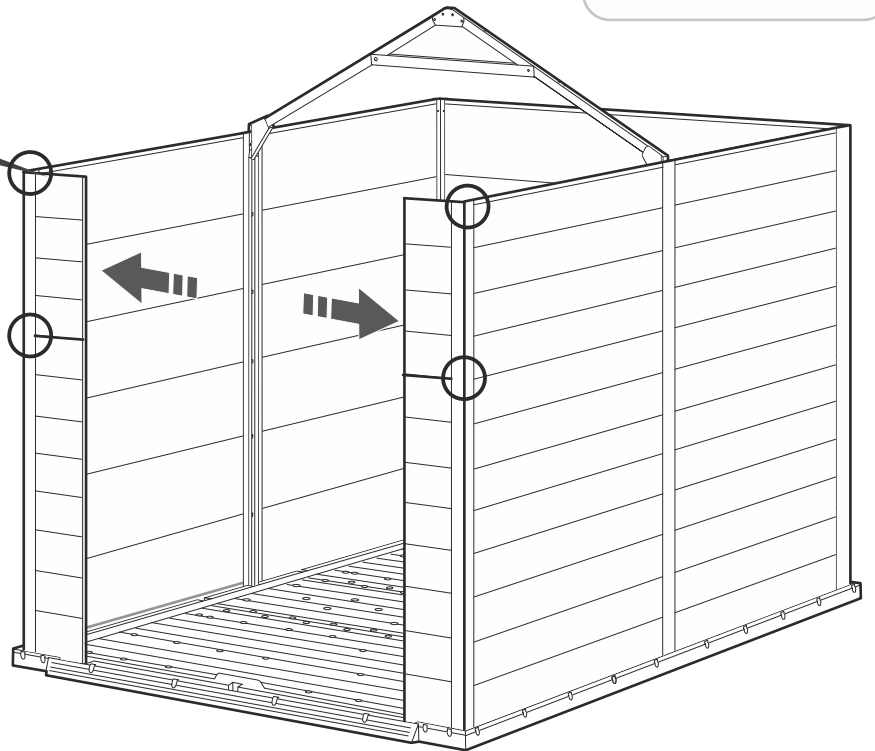

32



s13b (x8)

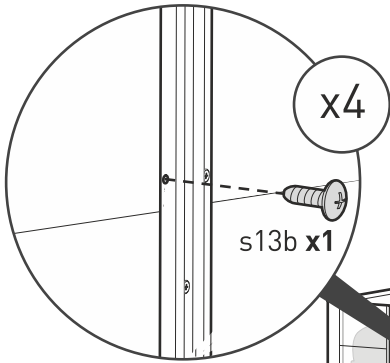
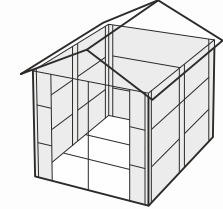

x4

s13b x1

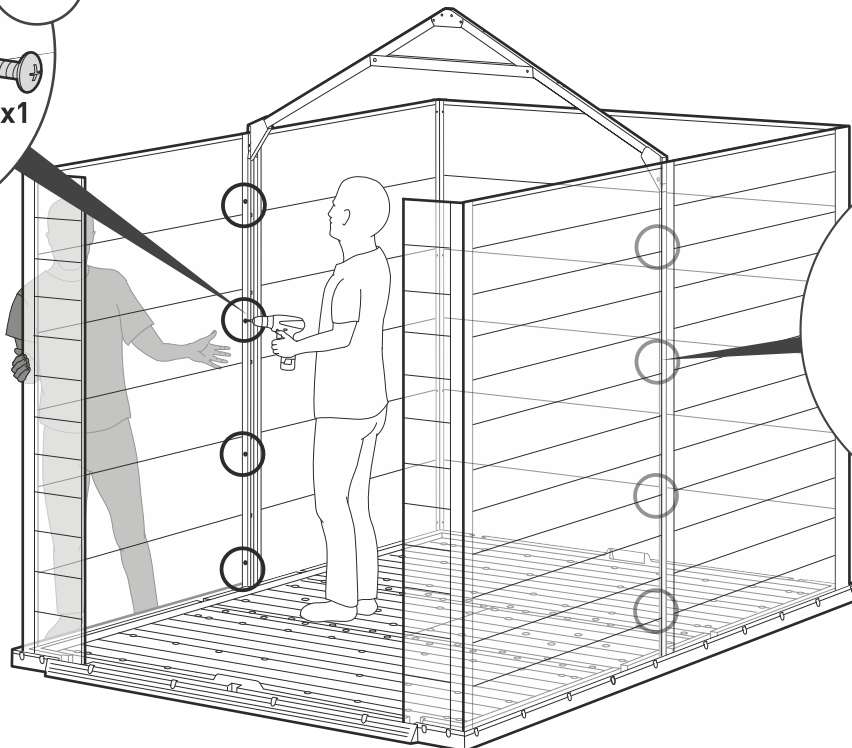

s13b x1

x4

33



NEFM (x1)



S45b (x2)

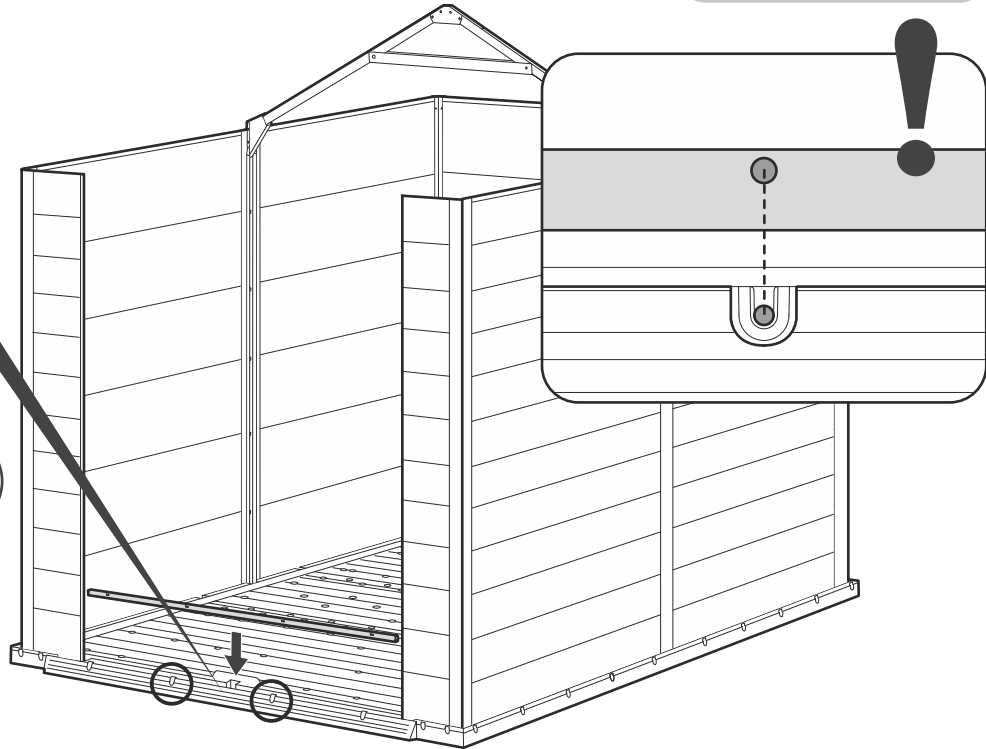
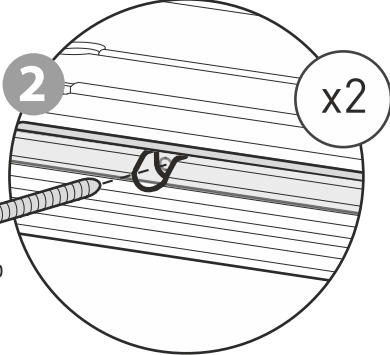
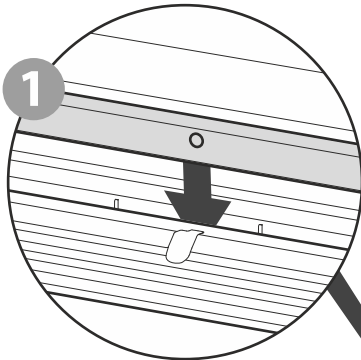
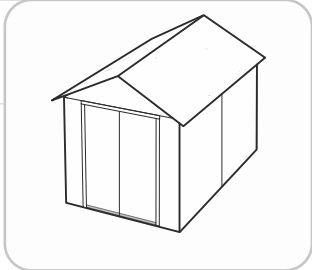

34



NEFM (x1)



S45b (x2)

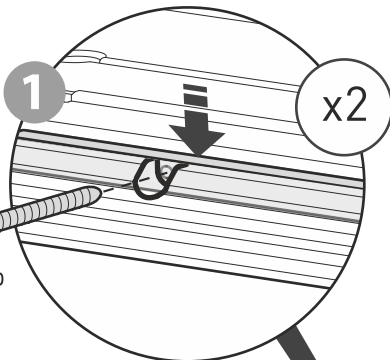
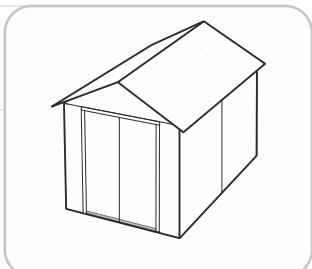



35



NELR (x2)

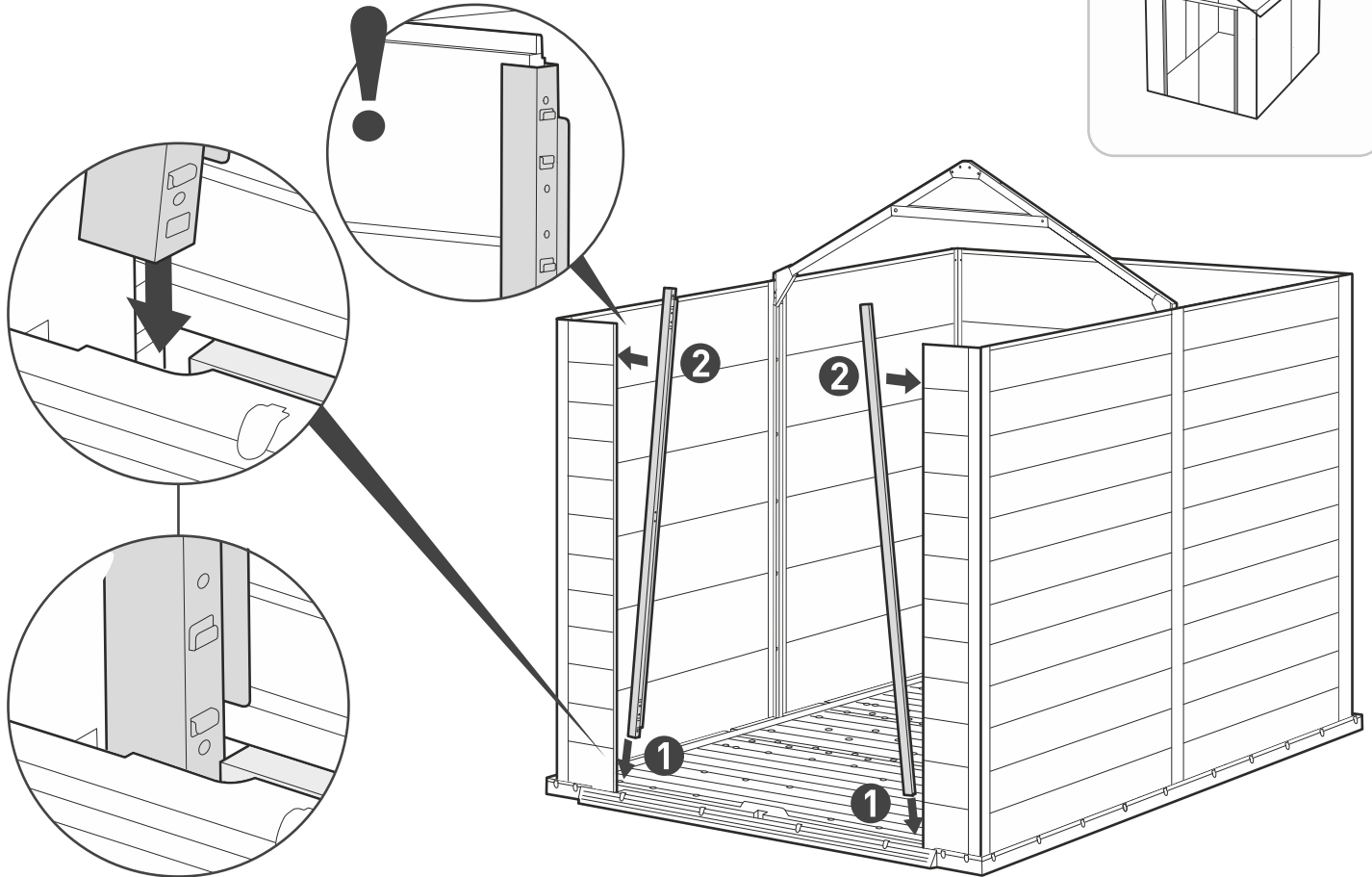
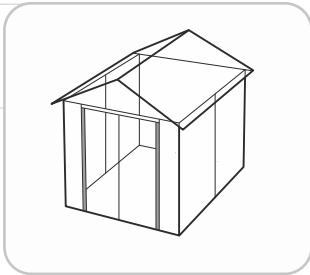

36



NEUK (x1)

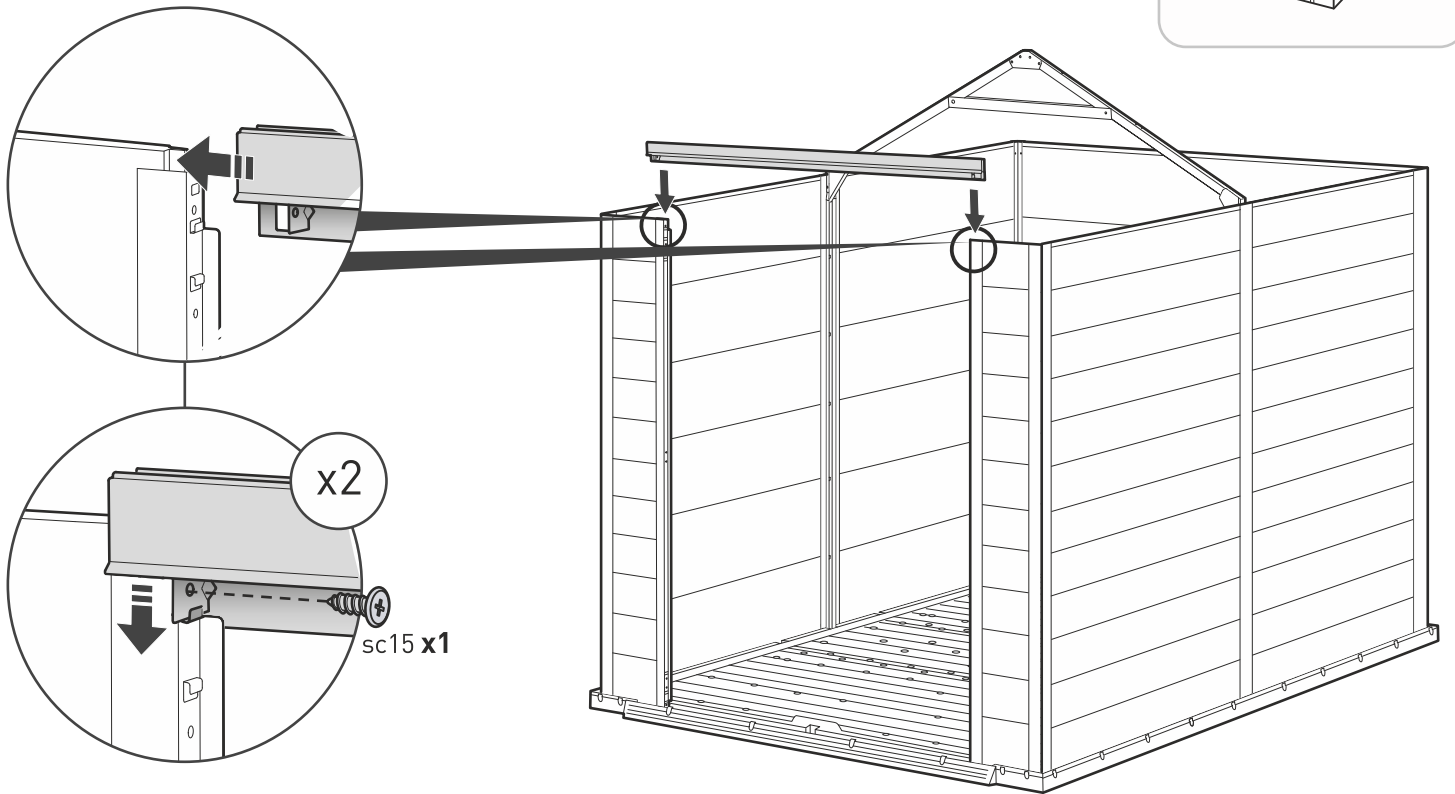
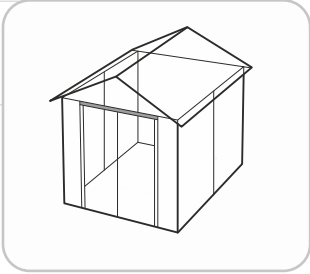

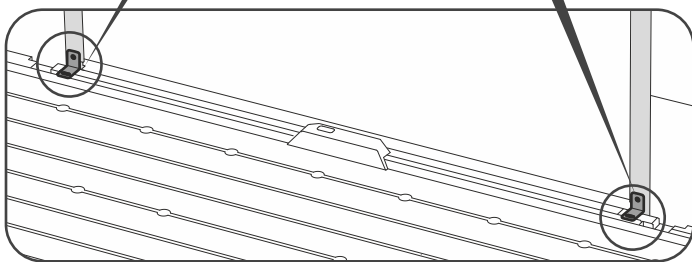
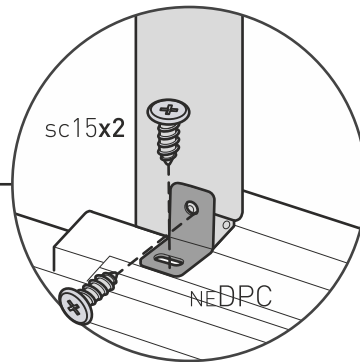
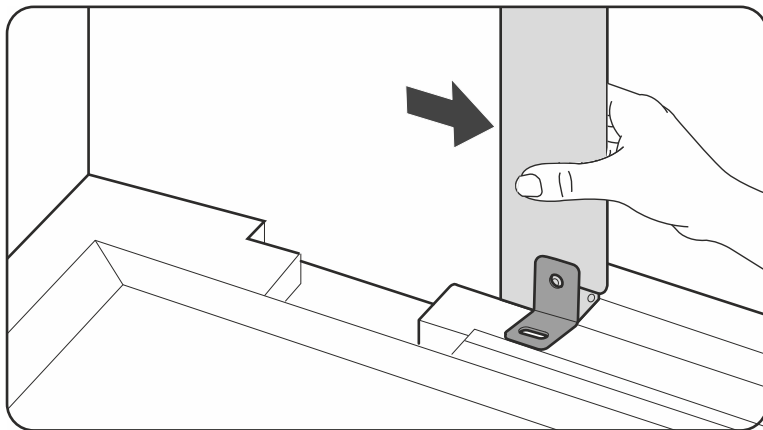
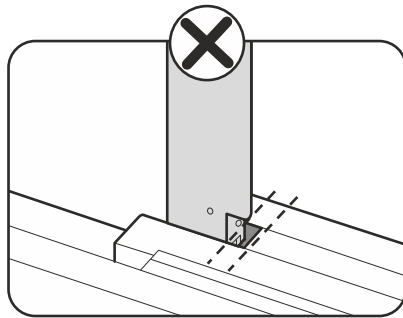
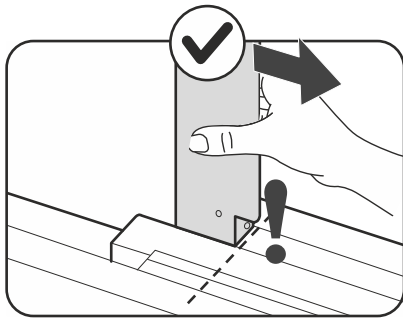
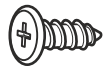

No pre-drilled holes | Pas de trous pré-perçés | Sin agujeros pretaladrados | Ohne vorgebohrte Löcher | Geen voorgeboorde gaten | Buchi preforati non presenti | Nincsenek előre kifúrt lyukak





FNAV (x1)

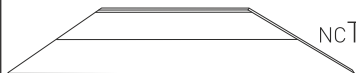

NC-TR (x1)



sc15 (x2)

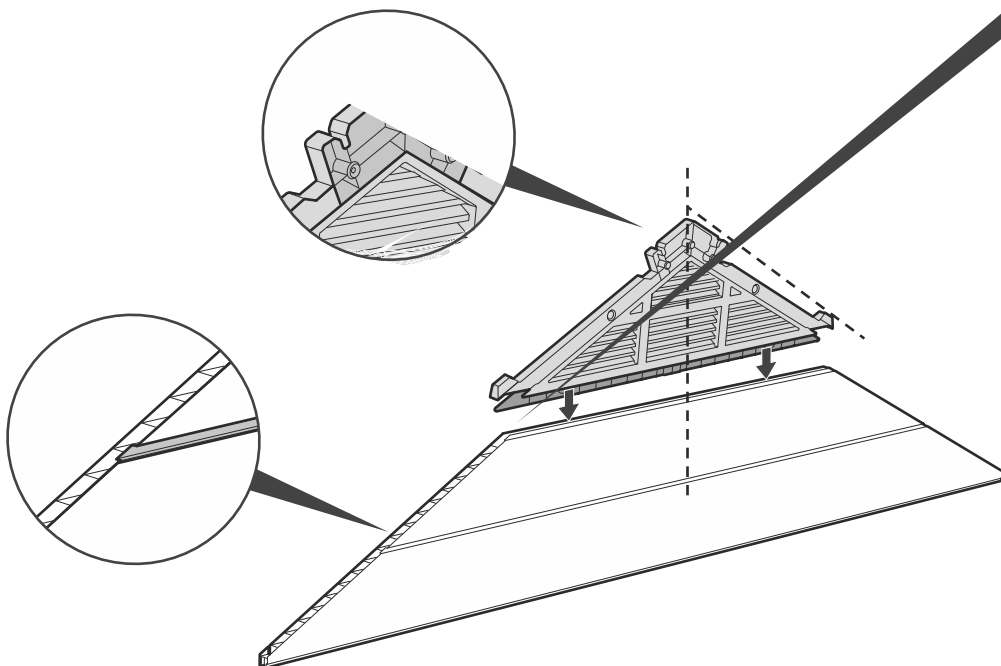
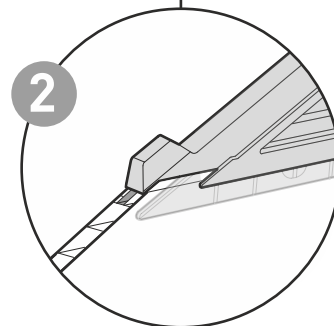
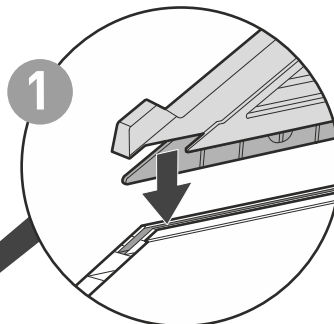
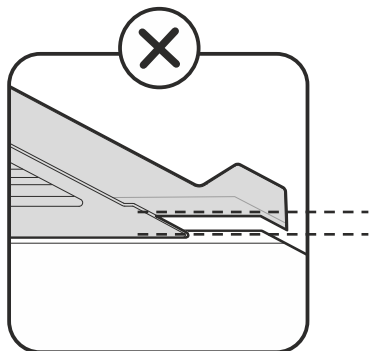
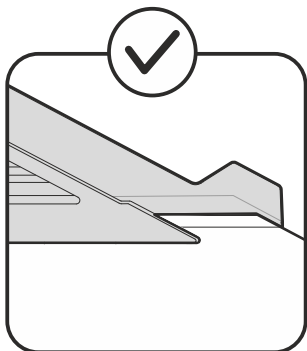
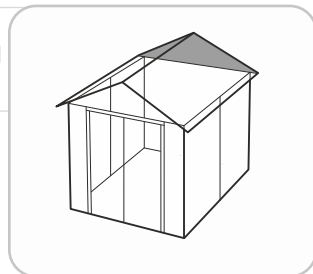

No pre-drilled holes | Pas de trous pré-perçés | Sin agujeros pretaladrados | Ohne vorgebohrte Löcher | Geen voorgeboorde gaten | Buchi preforati non presenti | Nincsenek előre kifúrt lyukak

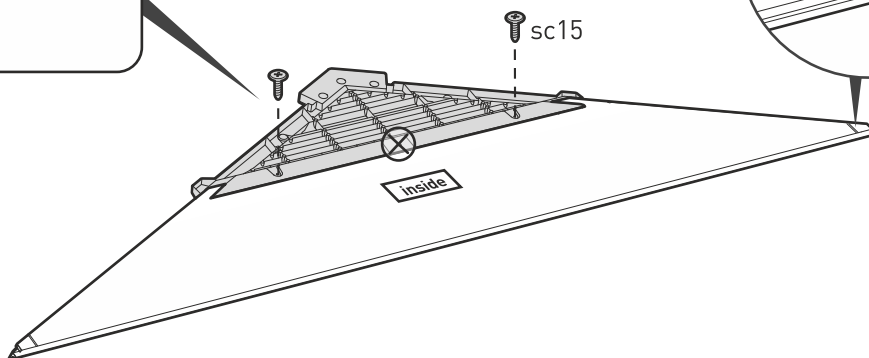
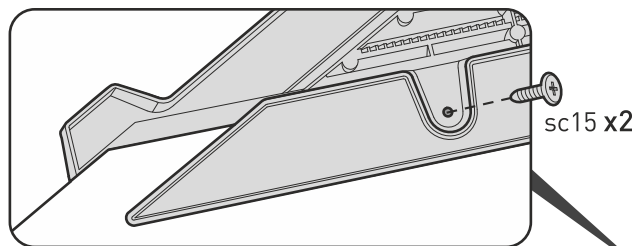

39

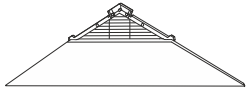

s13b (x2)

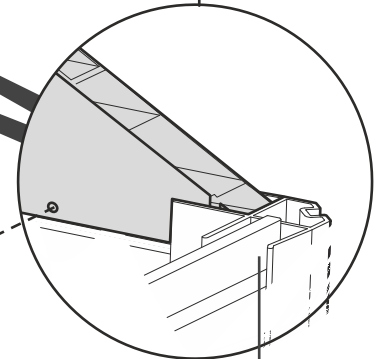
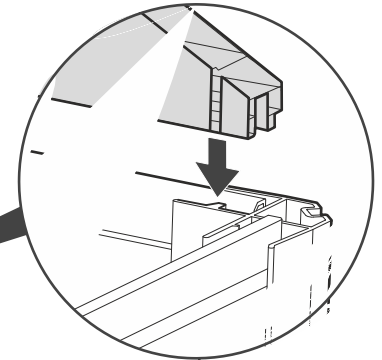
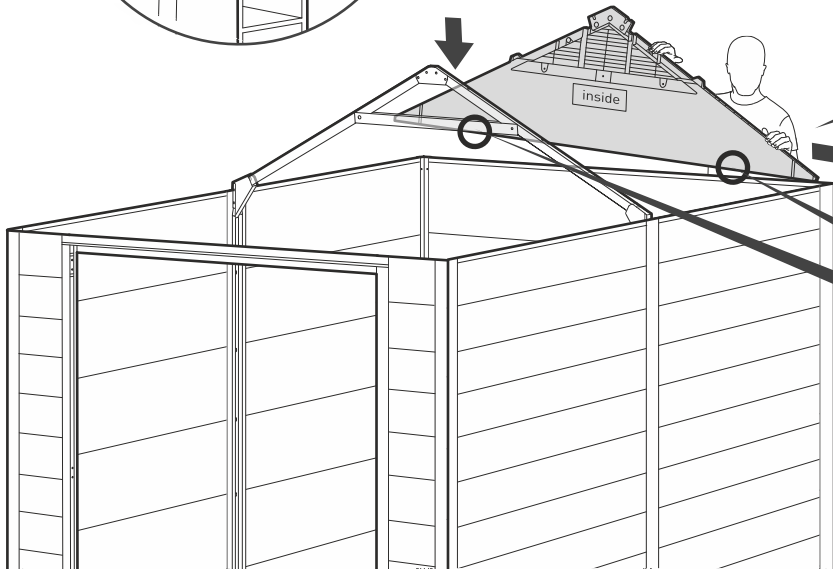
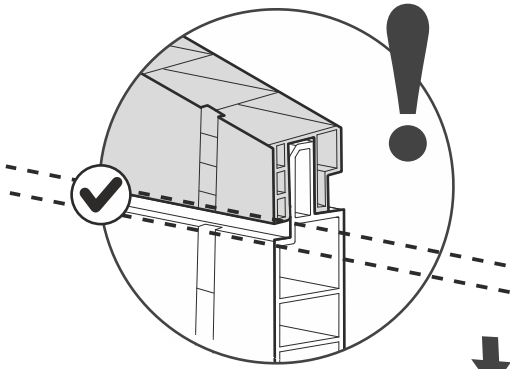
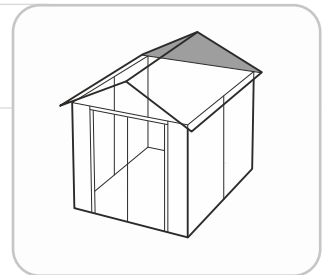

40

NE MBA (x1)



sc15 (x1)

s13b (x3)

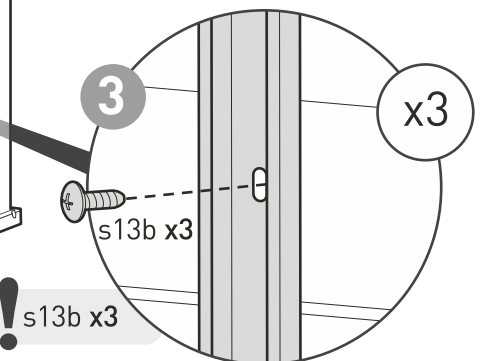
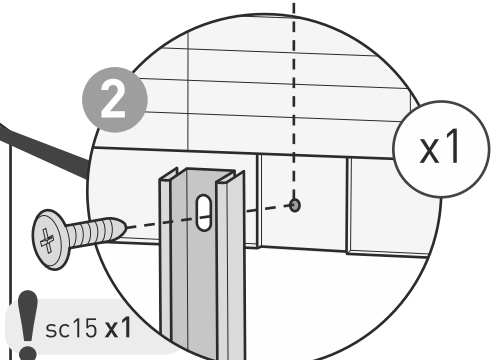
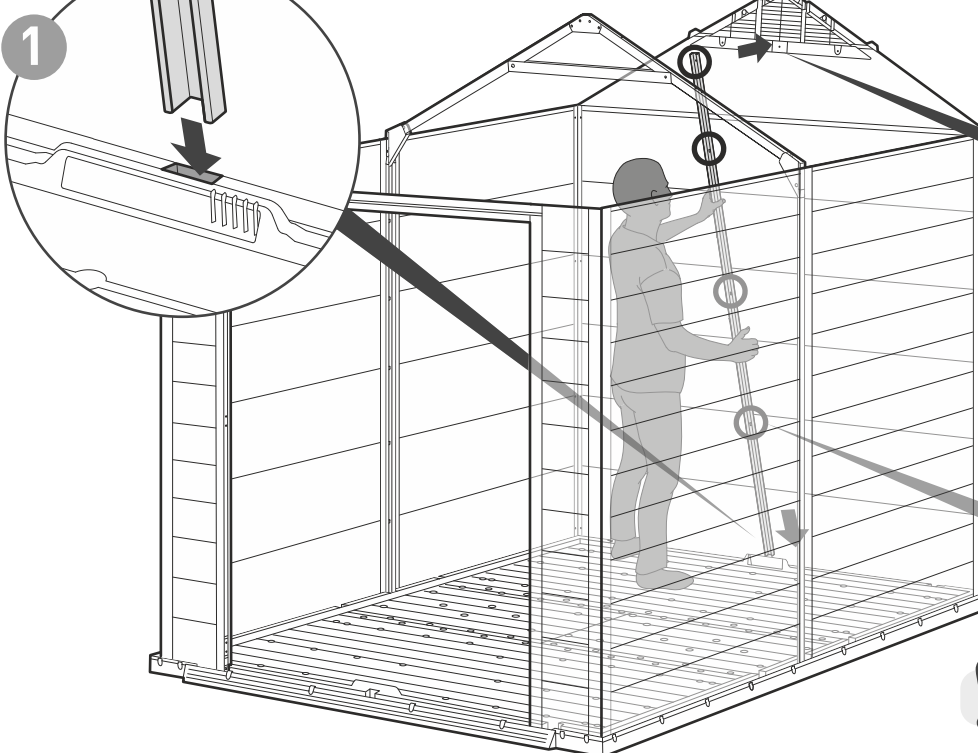
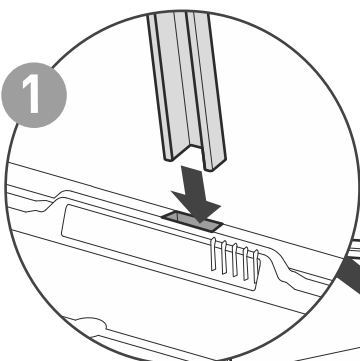
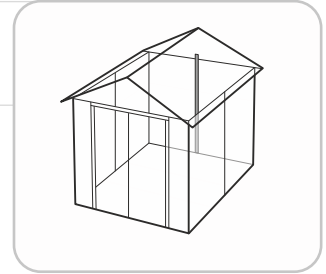

41



FNAV (x1)

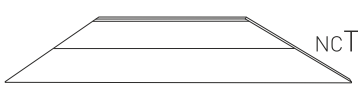

ncTR (x1)



sc15 (x3)

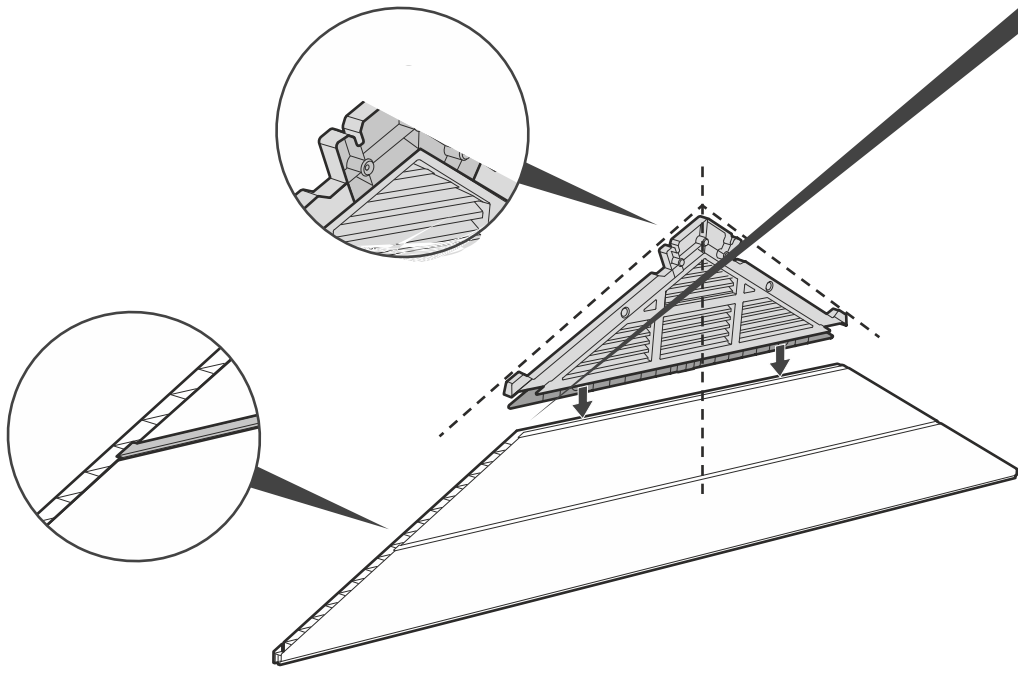
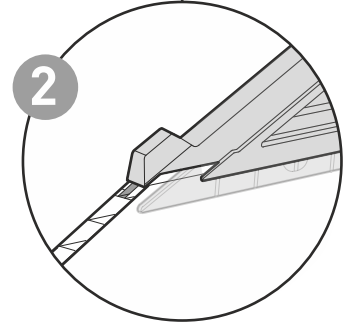
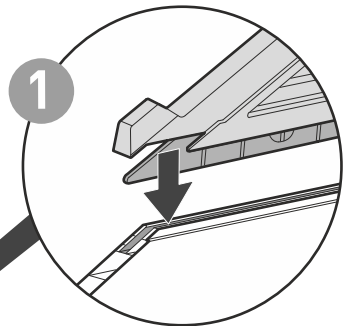
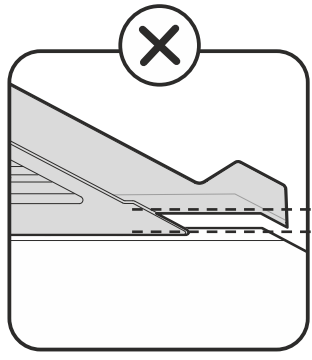
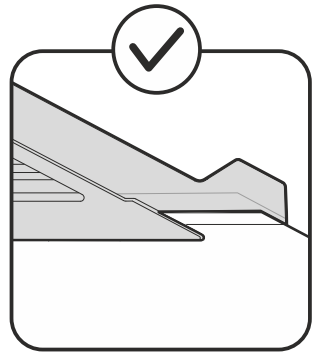
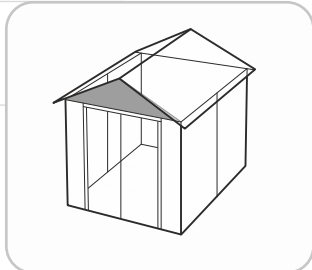

No pre-drilled holes | Pas de trous pré-perçés | Sin agujeros pretaladrados | Ohne vorgebohrte Löcher | Geen voorgeboorde gaten | Buchi preforati non presenti | Nincsenek előre kifúrt lyukak

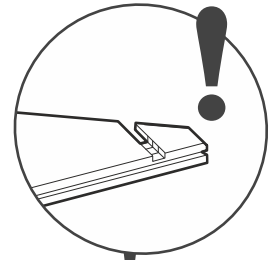
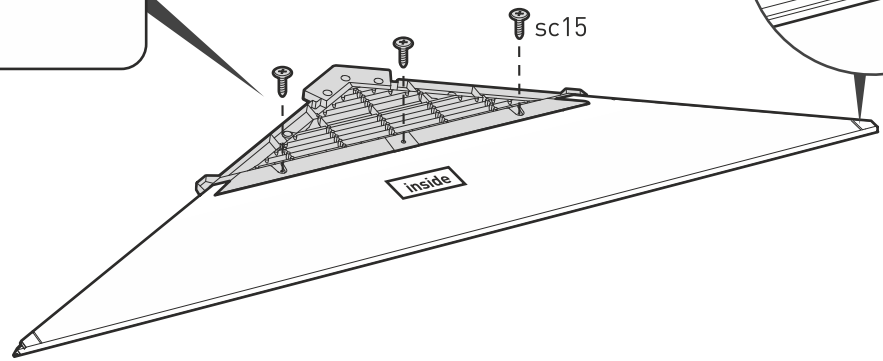
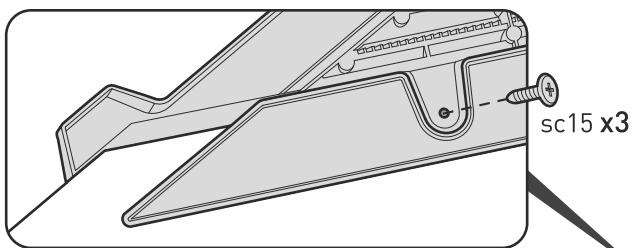

42

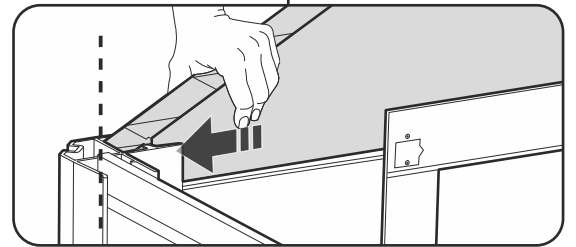
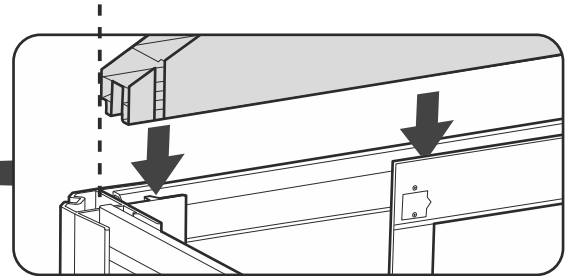
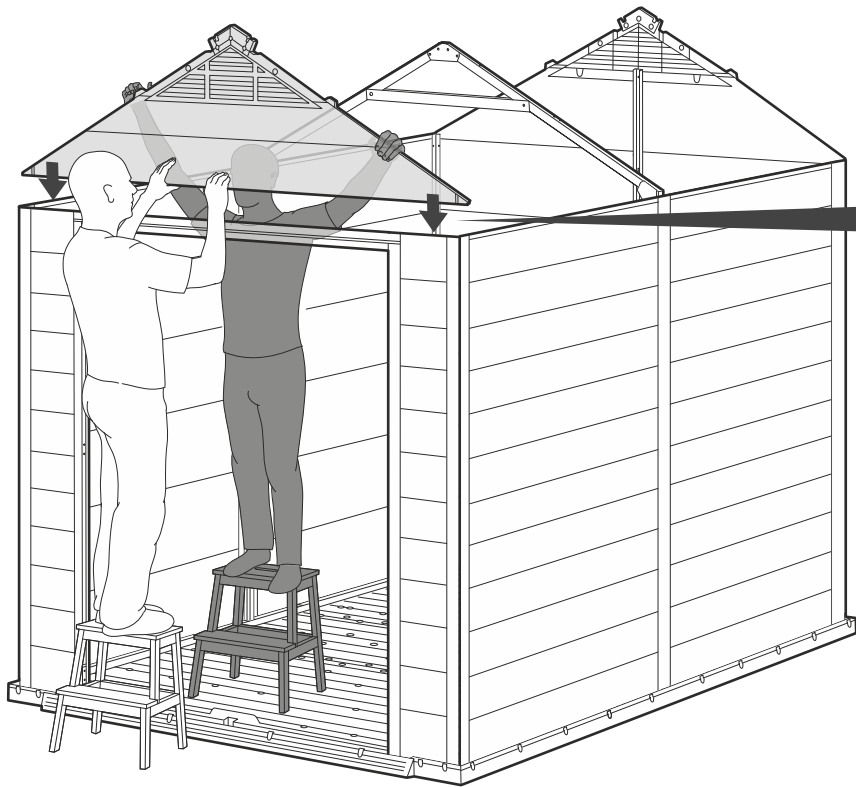
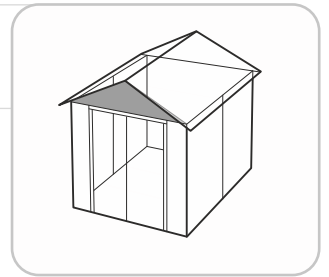
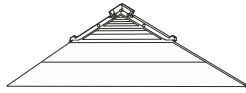

43

 s13b (x2)

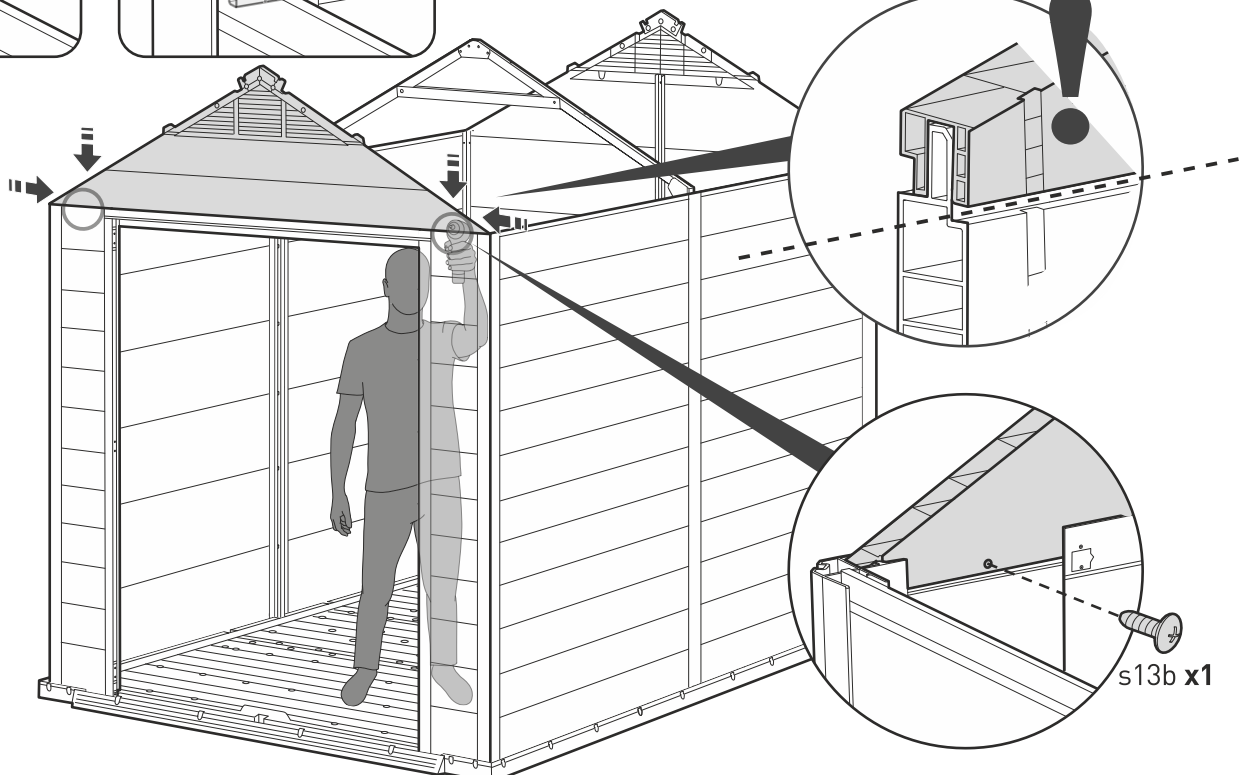
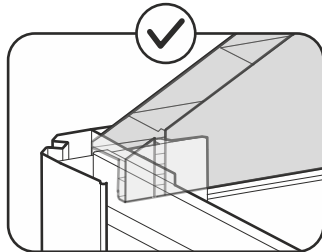
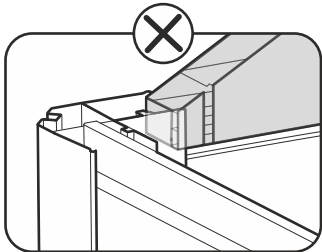
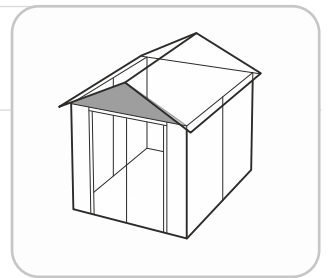



MOFTD (x2)



MOFTU (x2)

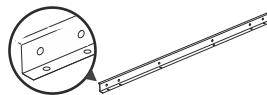

MOFM7 (x4)



sc15 (x20)

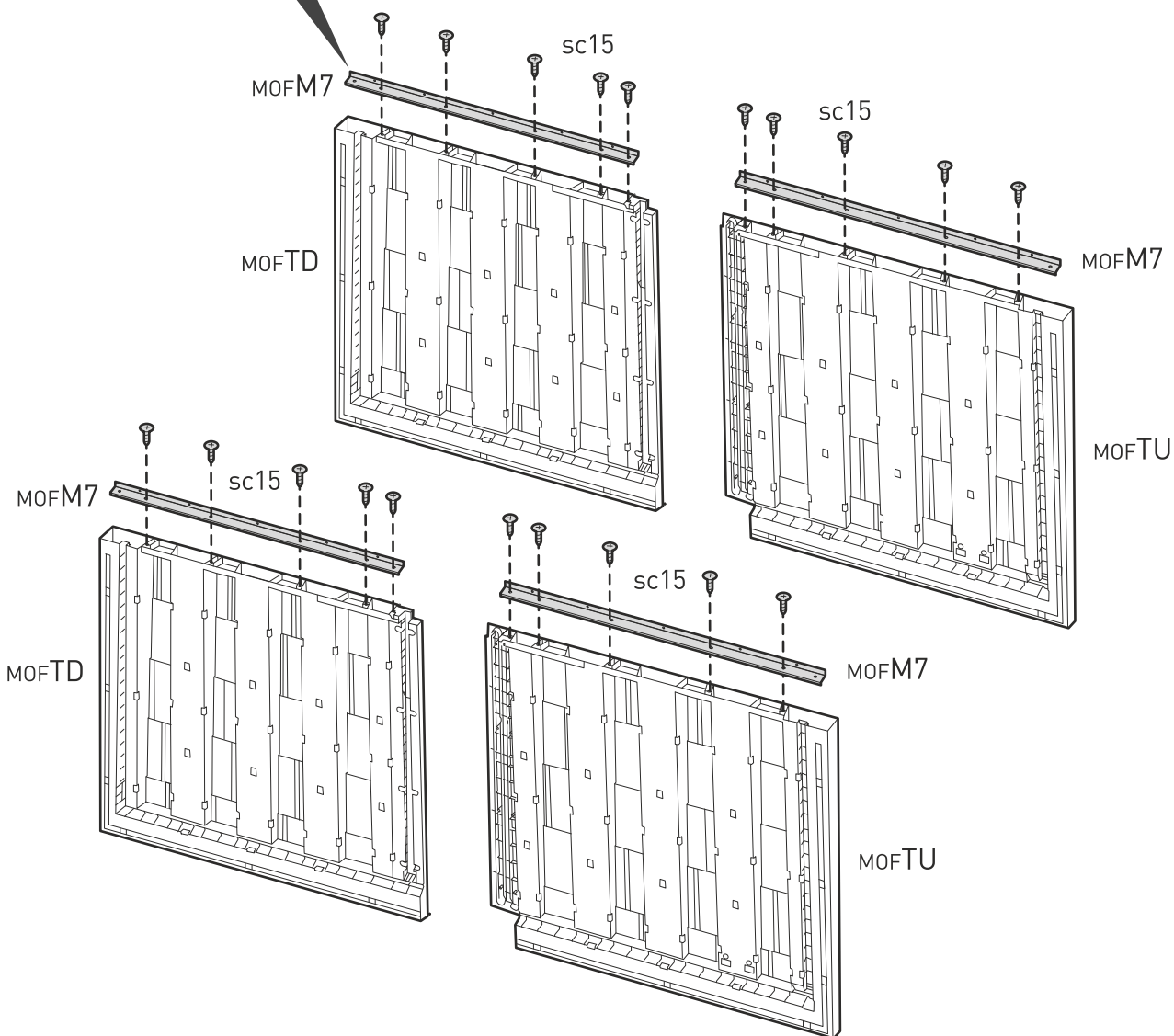
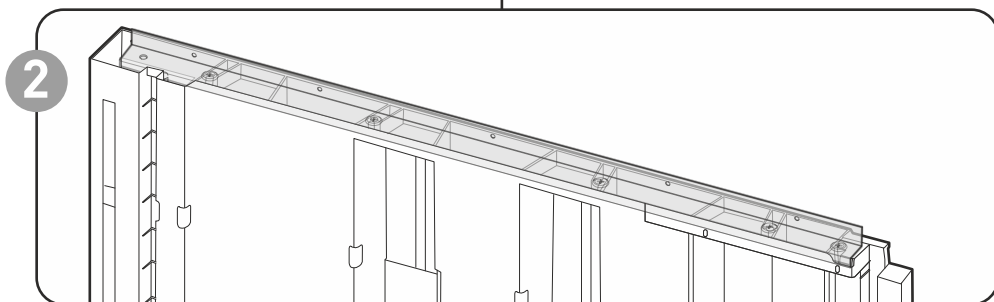
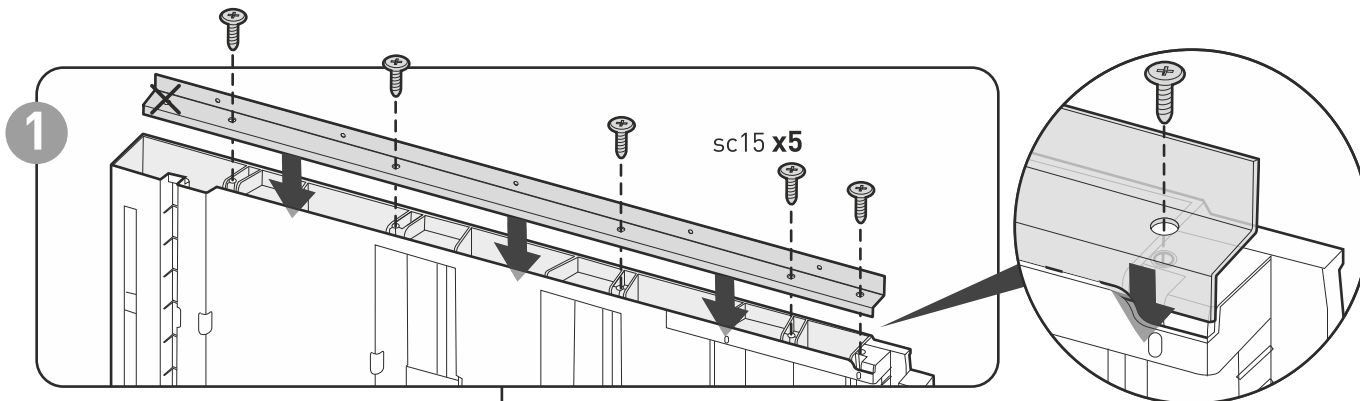

45



MOFTD (x1)

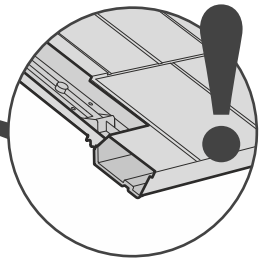
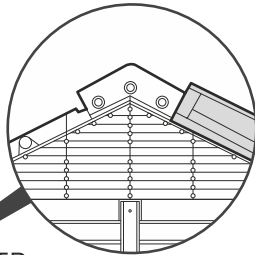
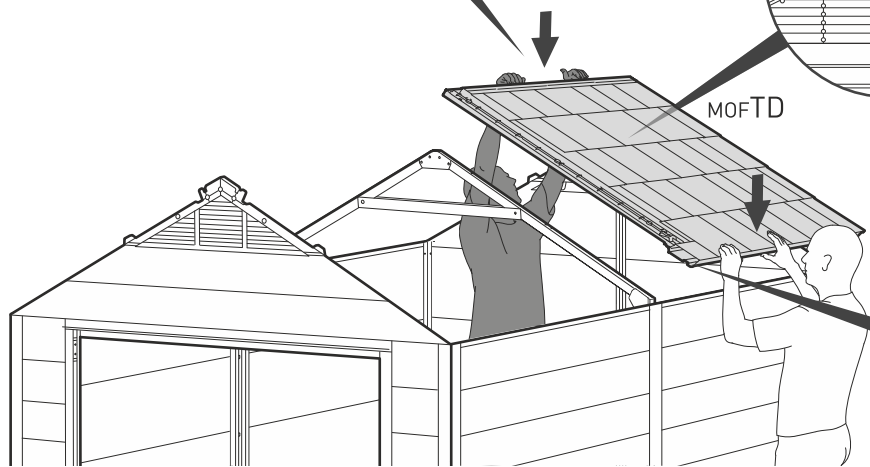
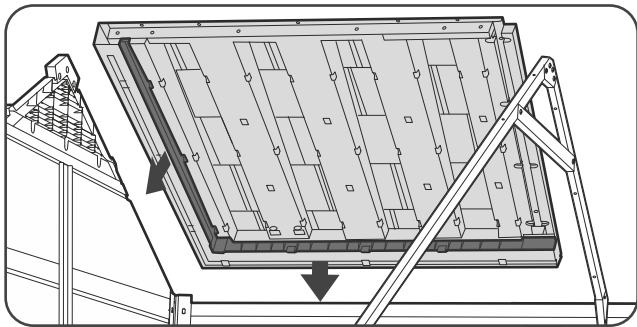
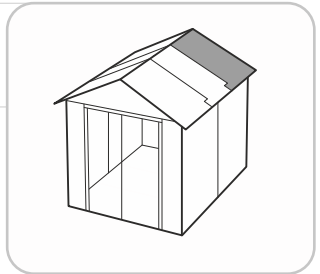

46



MOFT9 (x1)



sc15 (x1)

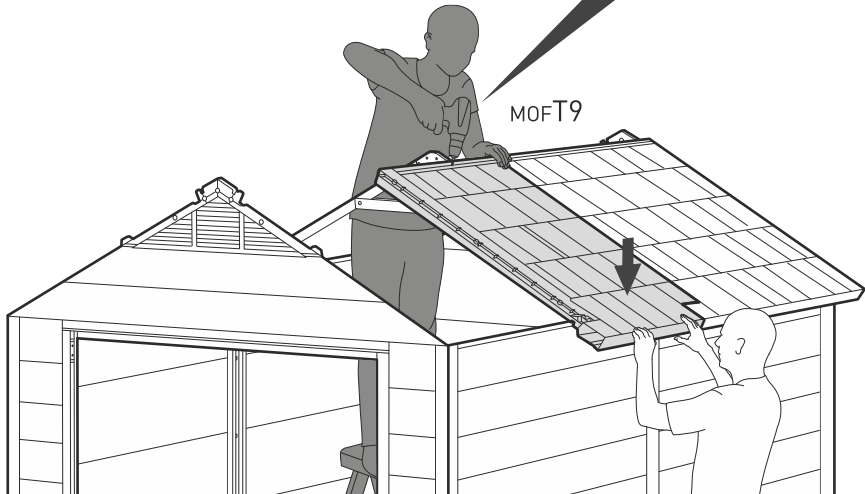
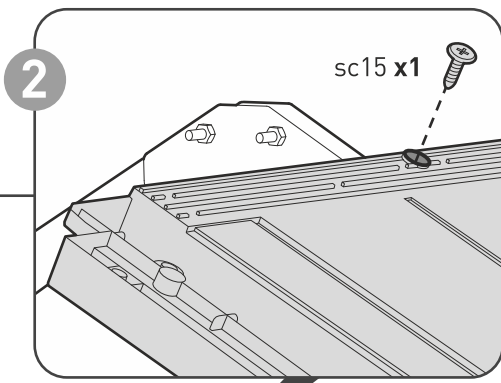
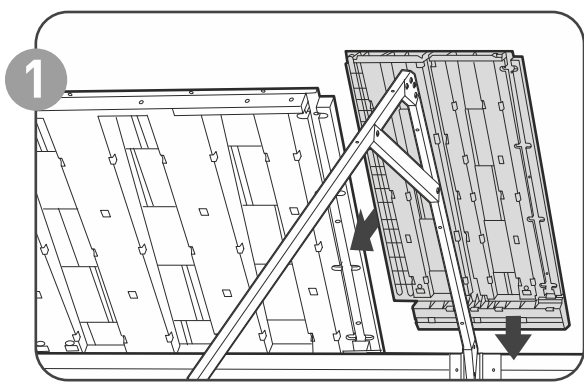
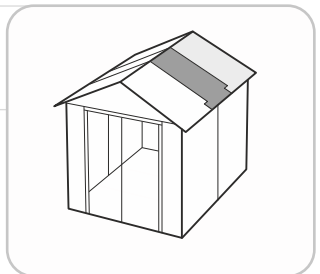



47

sc15 (x8)

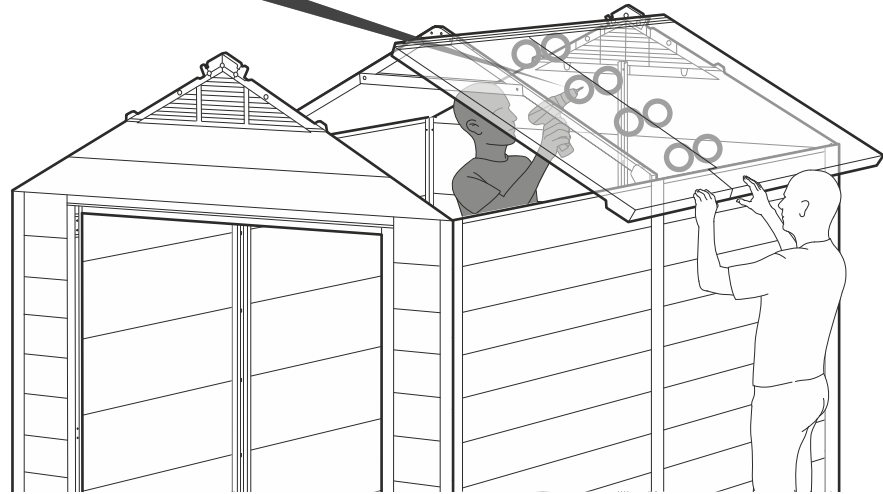
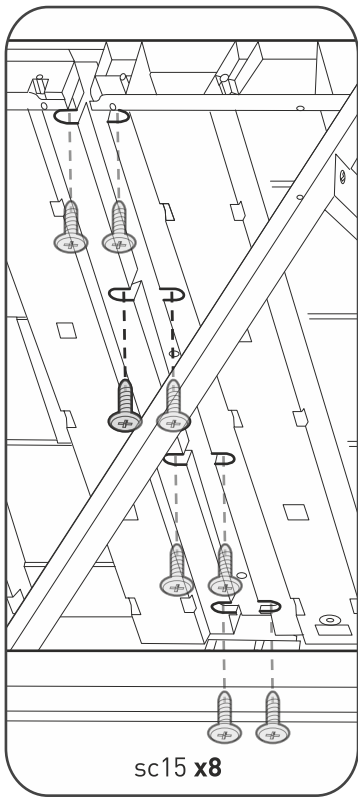
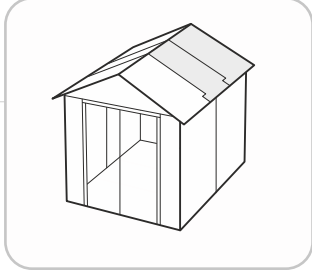

48

M0FTU (x1)

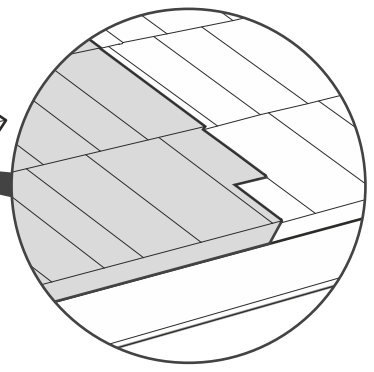
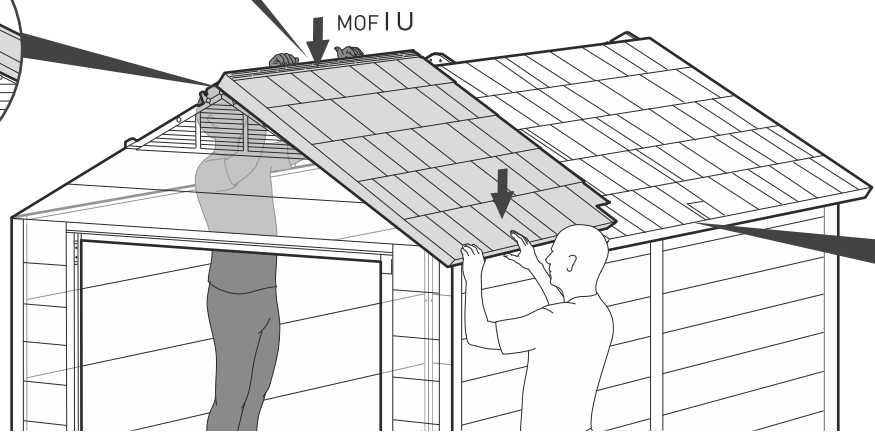
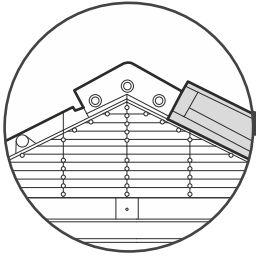
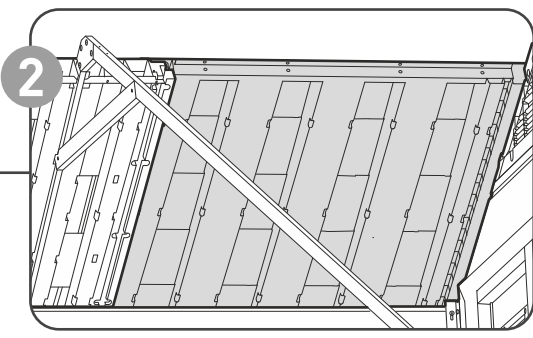
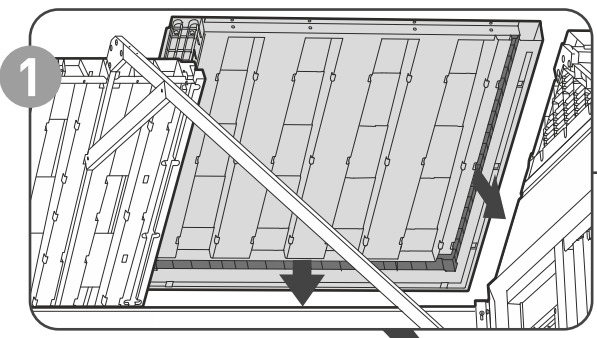
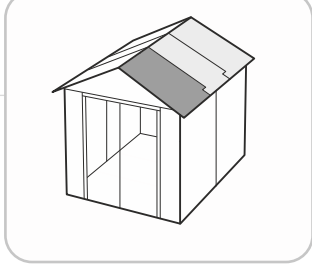

49

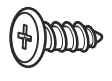

sc15 (x8)

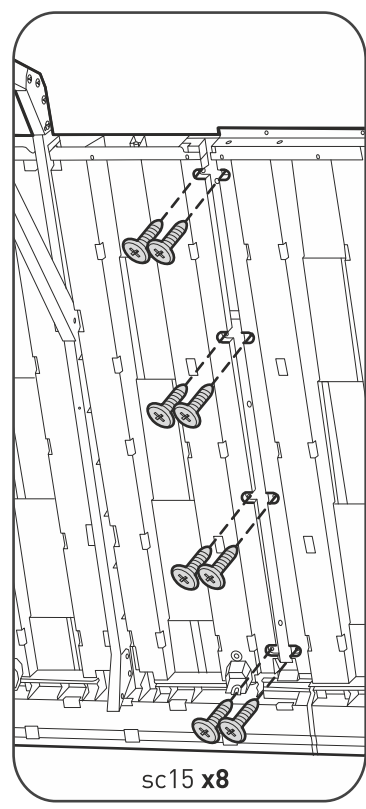
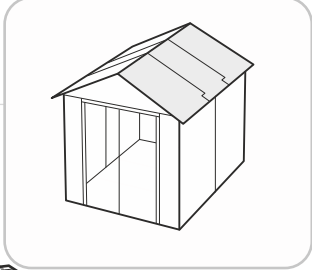

sc15 x8

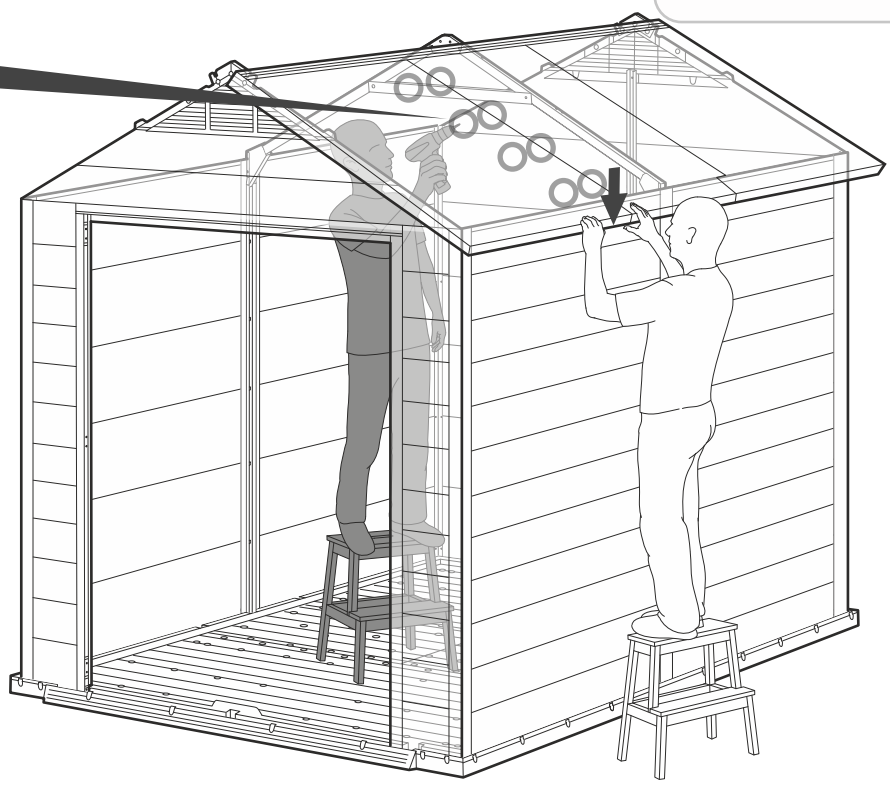

50



MoFTD (x1)

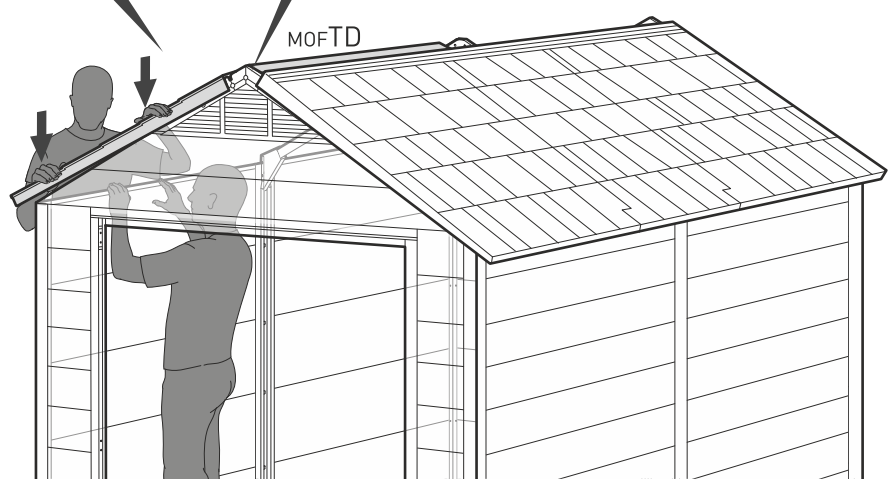
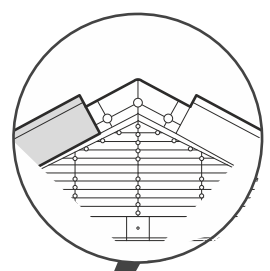
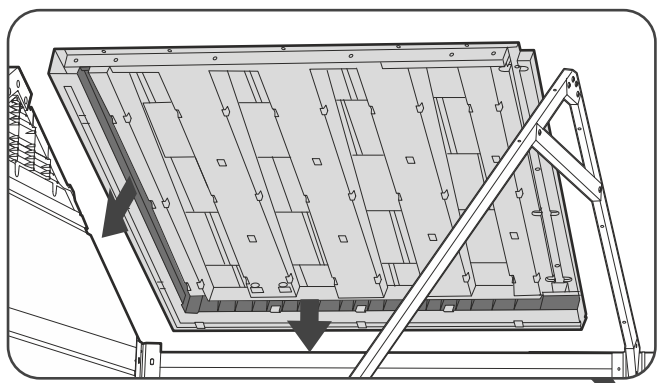
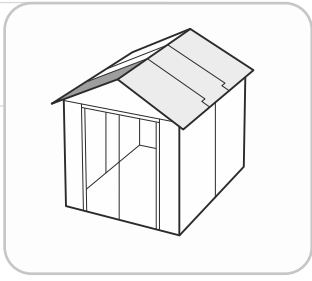

51

MOFT9 (x1)



sc15 (x1)

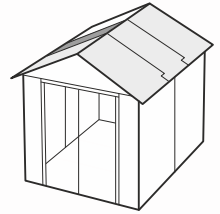

1

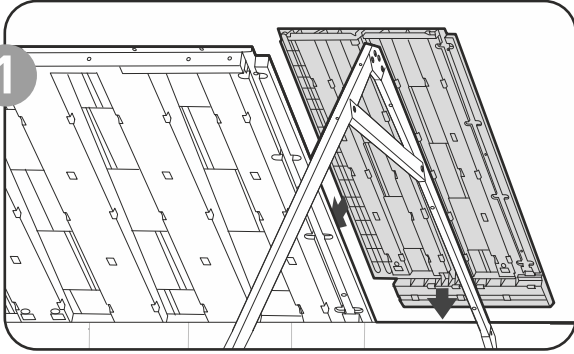

2

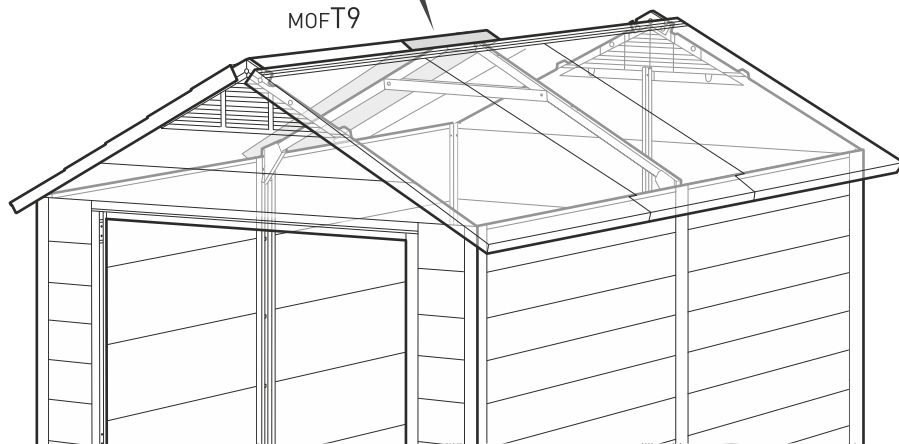
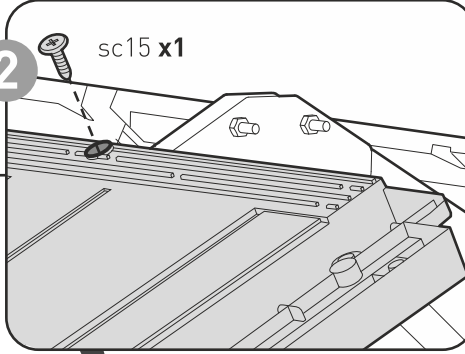

52

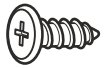

sc15 (x8)

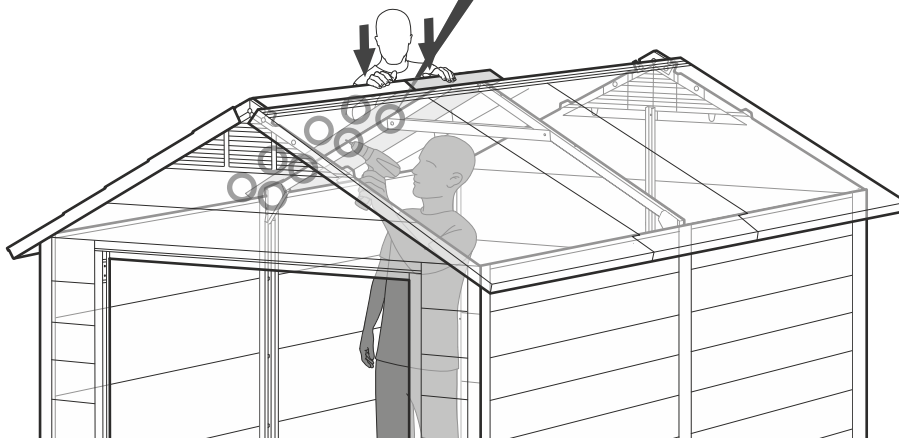
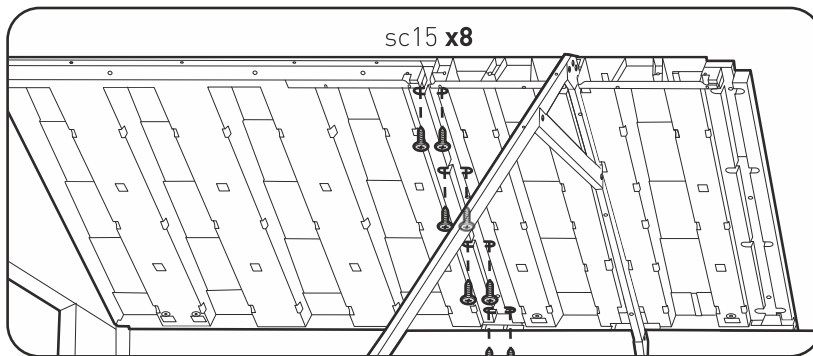
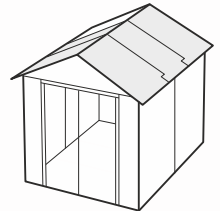

53

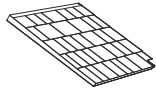

MOFTU (x1)

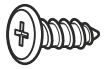

sc15 (x8)

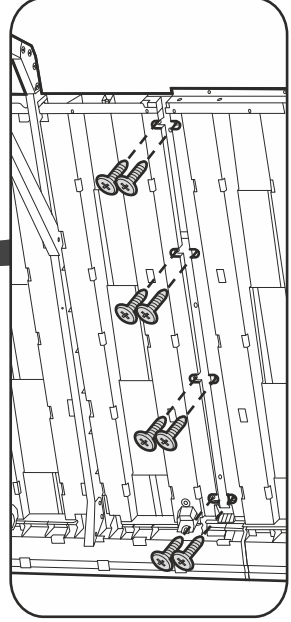
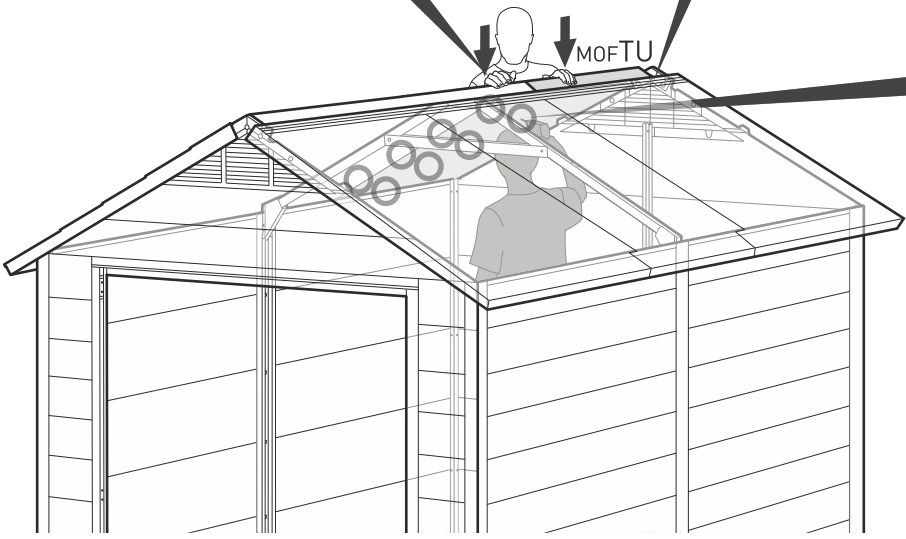
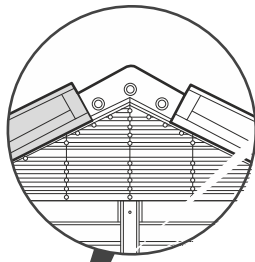
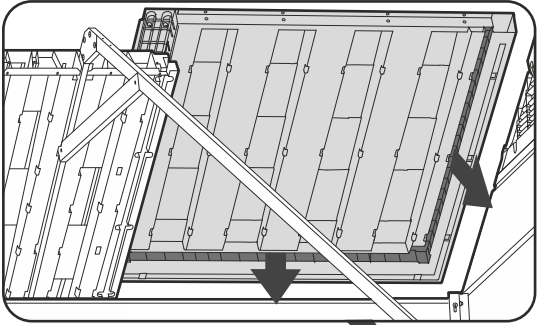
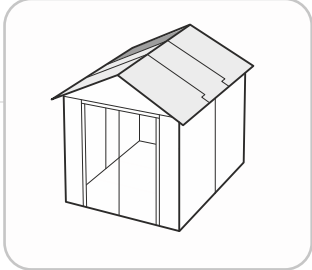

sc15 x8

54

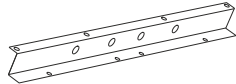

MOFM9 (x4)

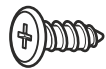

sc15 (x16)

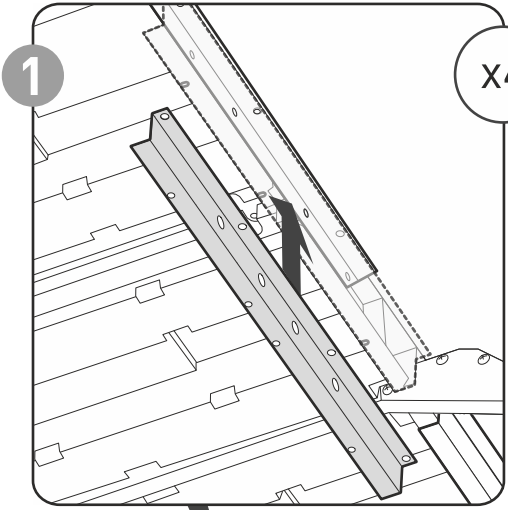

1

x4

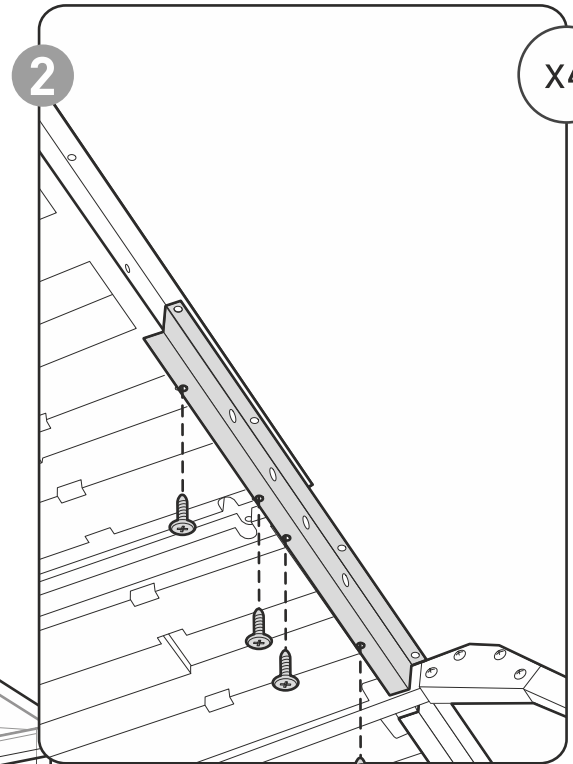

2

x4

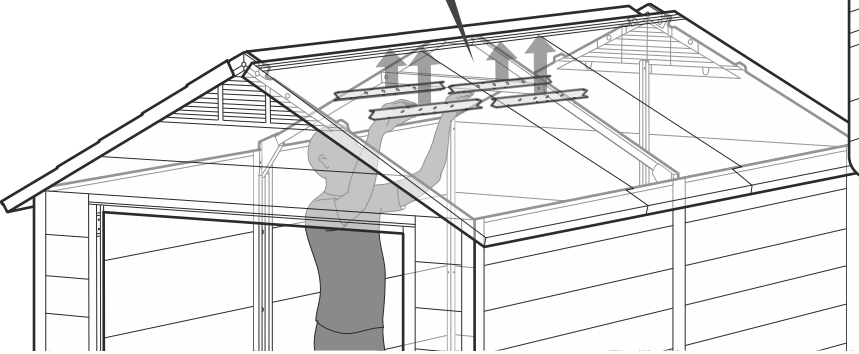

sc15 x4

55

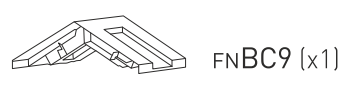

FNBC9 (x1)

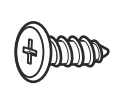

sc15 (x4)

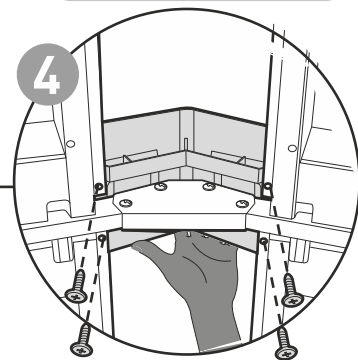
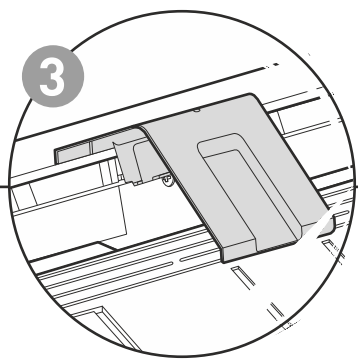
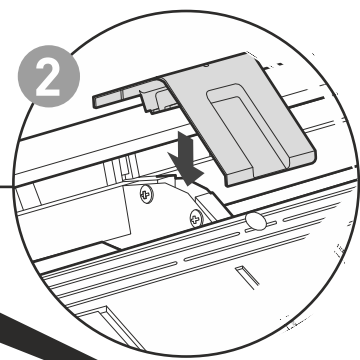
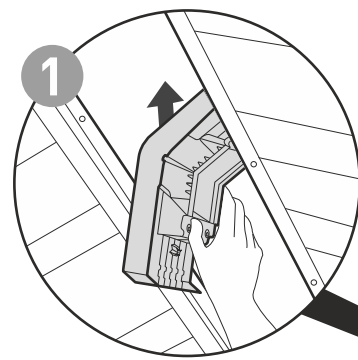
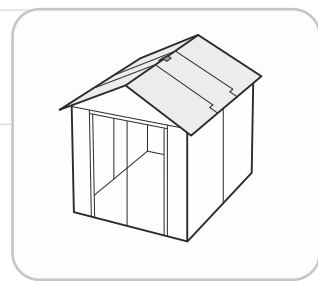

sc15 x4

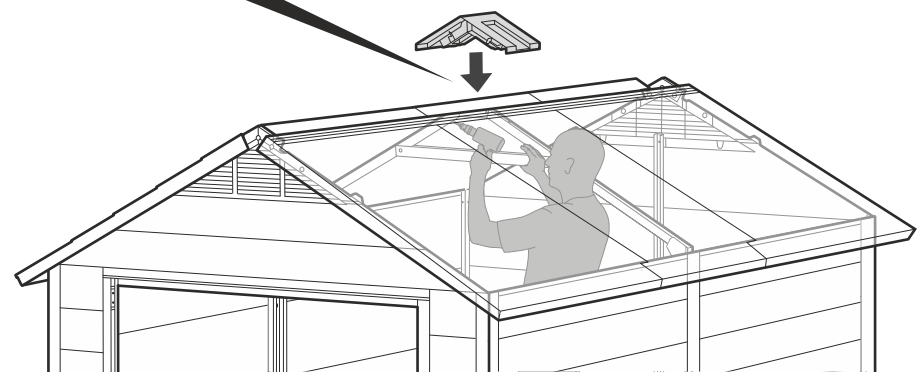

56



FNB9 (x2)



FNPLS (x2)

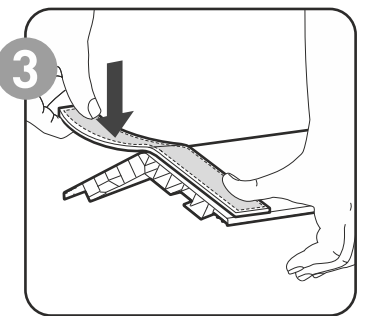
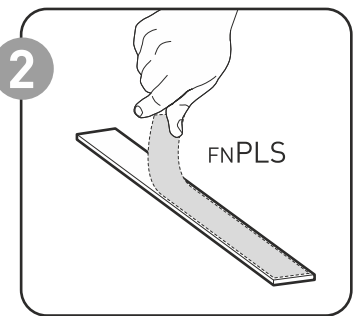
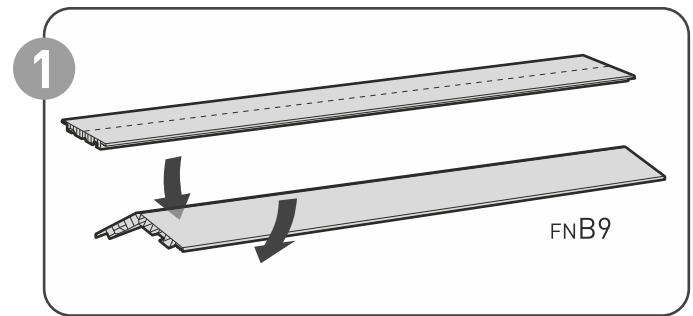
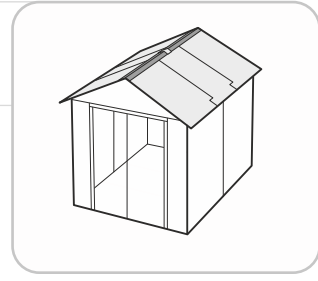

x2

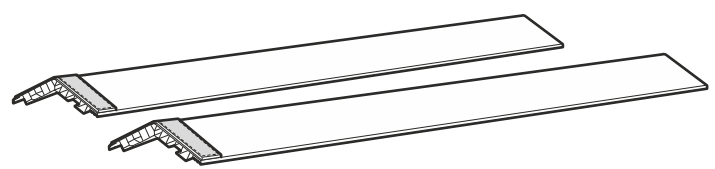

57

 (x2)

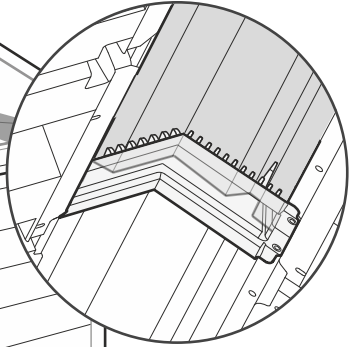
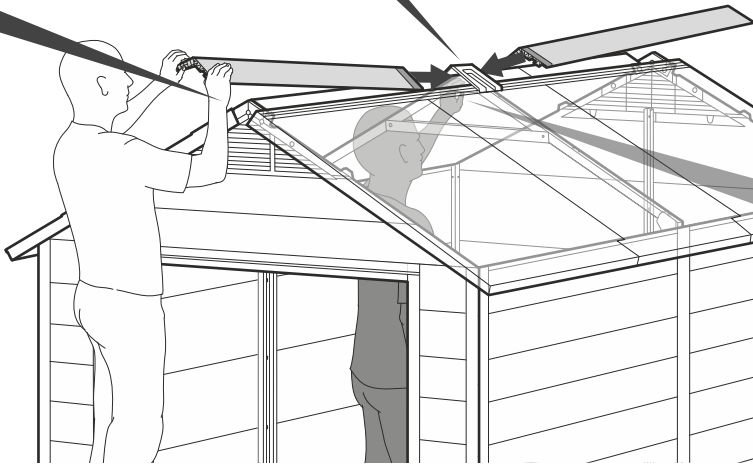
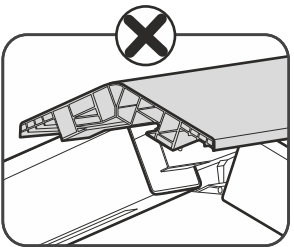
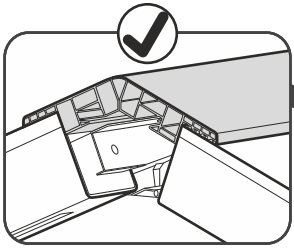
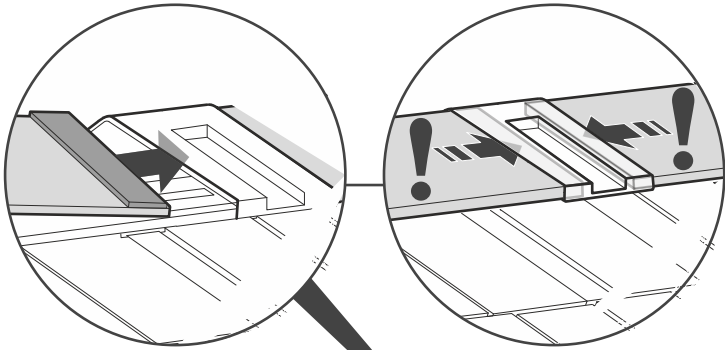
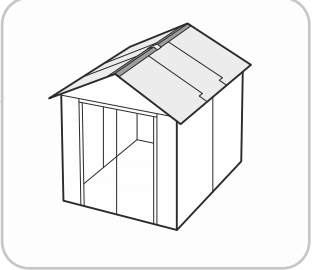

58

 FNAC (x2)

 s26b (x6)

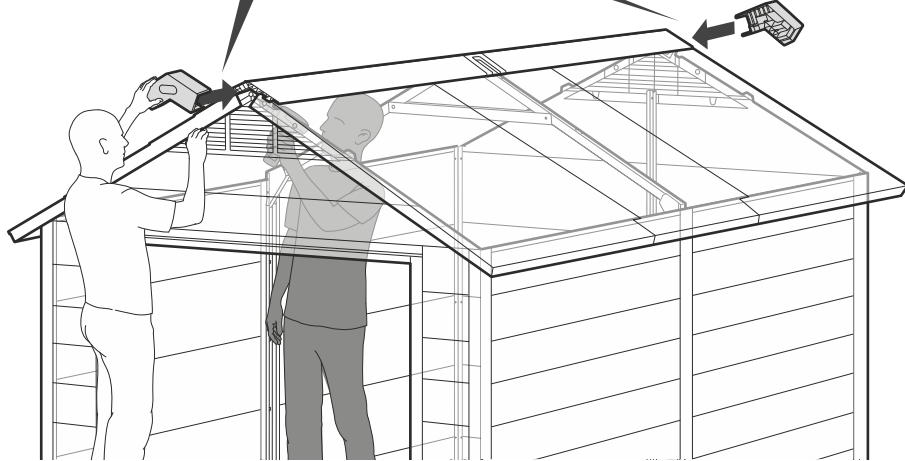
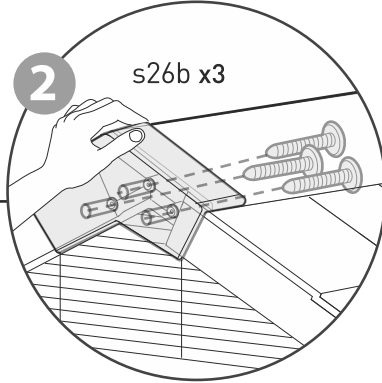
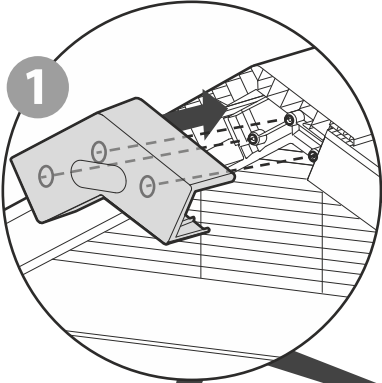
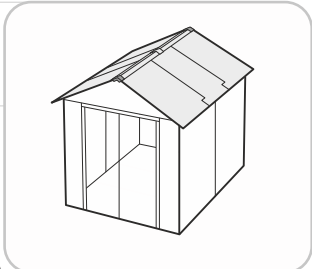

59

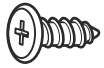

sc15 (x24)

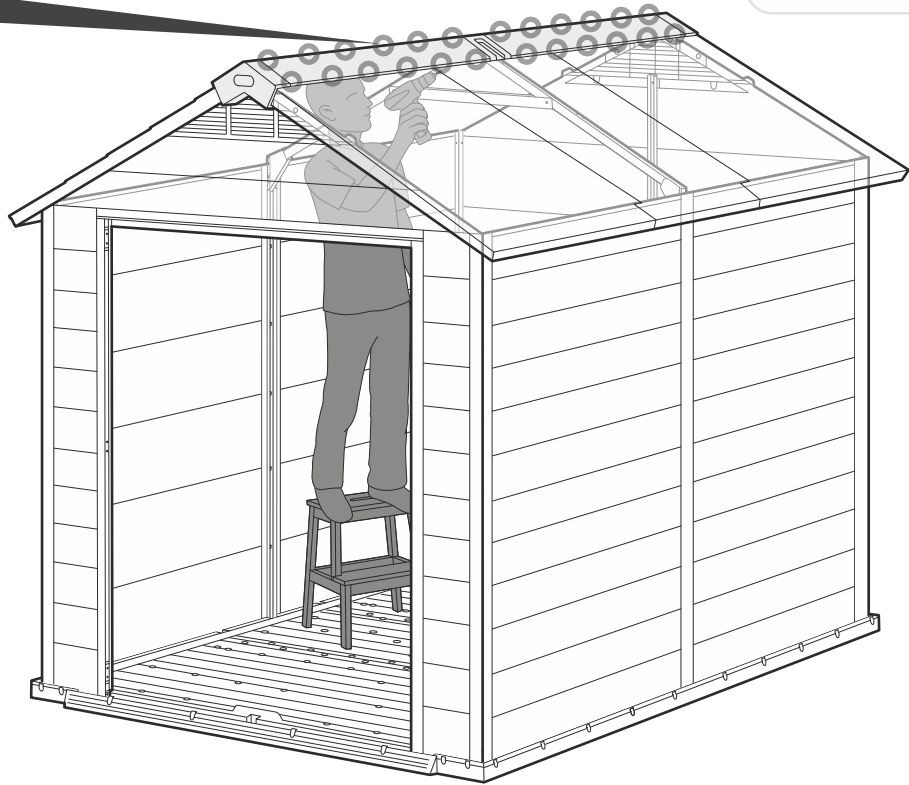
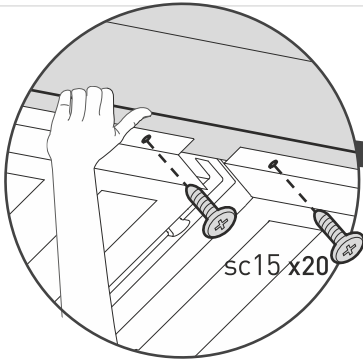
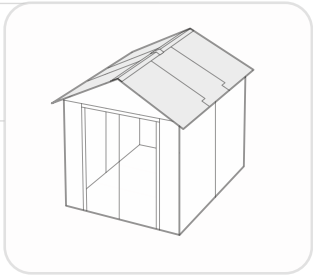

60

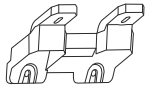

MOFTC (x4)



sc15 (x8)



s45b (x8)

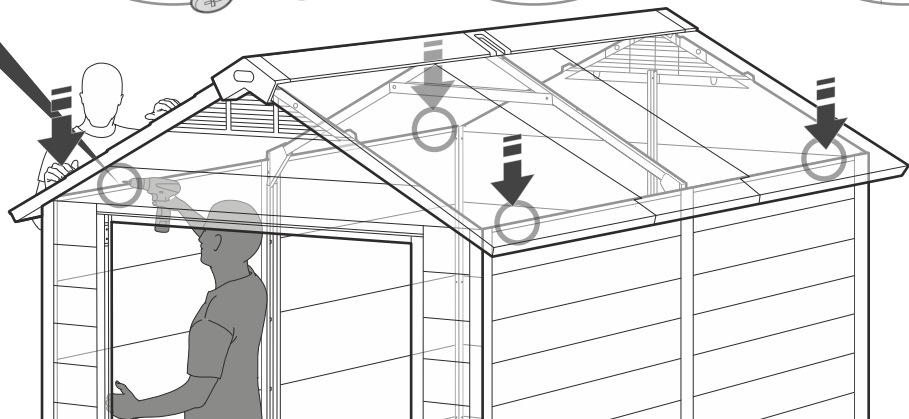
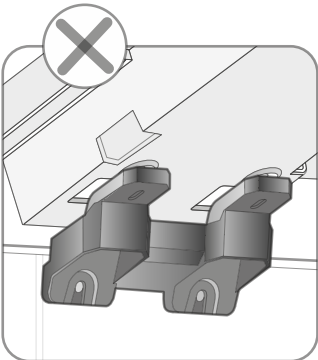
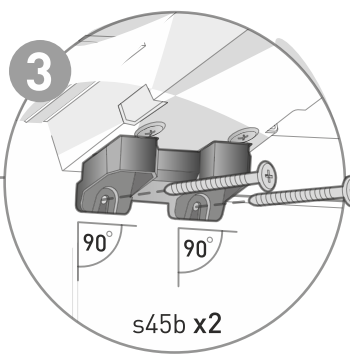
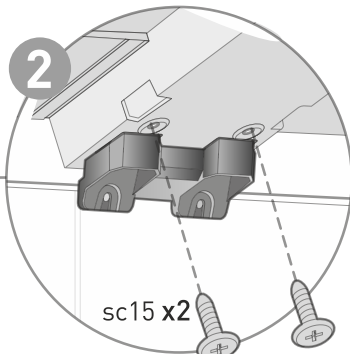
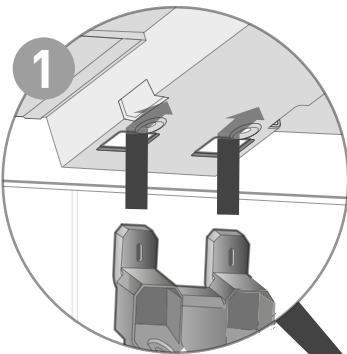
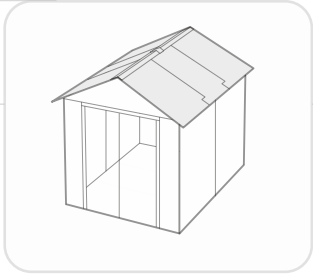

61

FNTM (x4)

sc15 (x4)

s45b (x4)

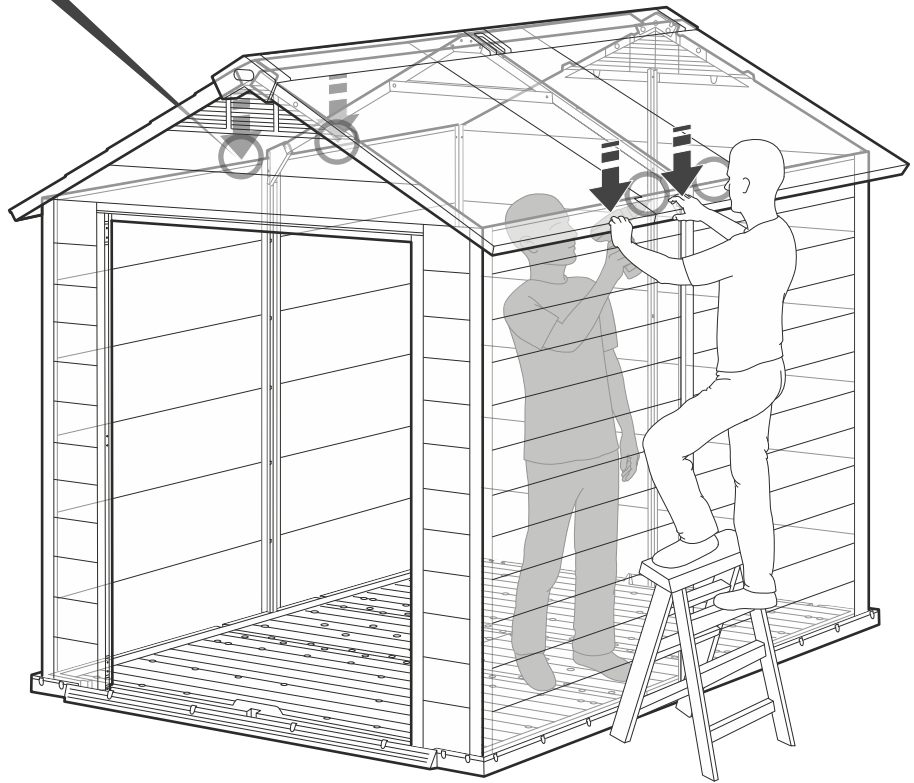
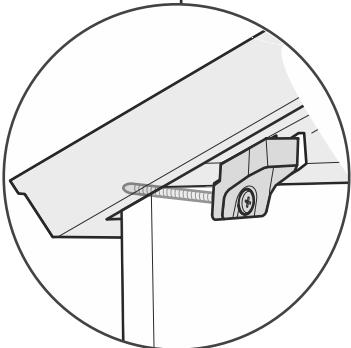
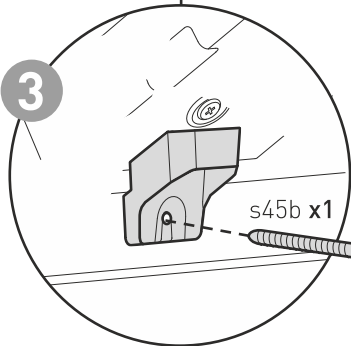
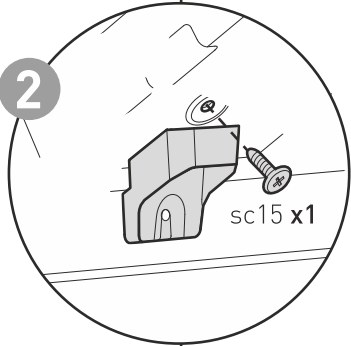
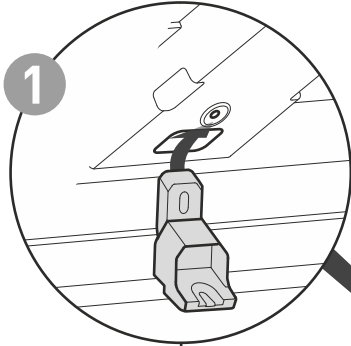
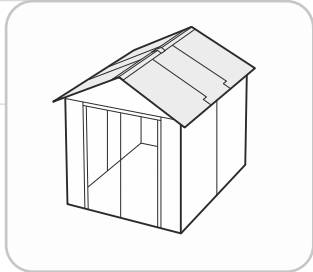



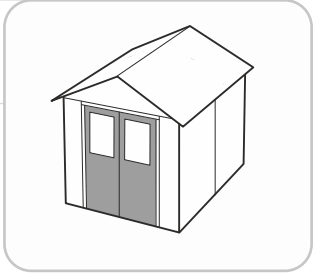

DOOR ASSEMBLY | MONTAGE DE LA PORTE | MONTAJE DE LA PUERTA | MONTAGE DER TÜR |  
 DEURMONTAGE | MONTAGGIO DELLA PORTA | MONTAGEM DA PORTA | AJTÓSZERELÉS

62 |  NEDC (x4) |  NEDMC (x8) |  sf13 (x16)

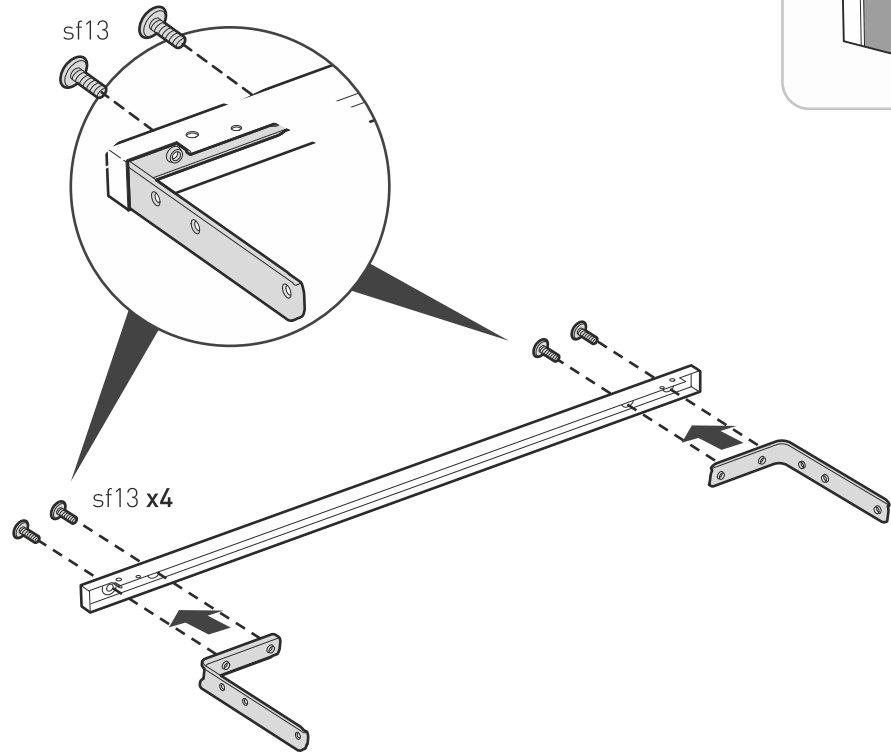

x4

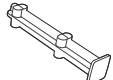

63 |  NUHF (x2) |  NEDDR (x1)

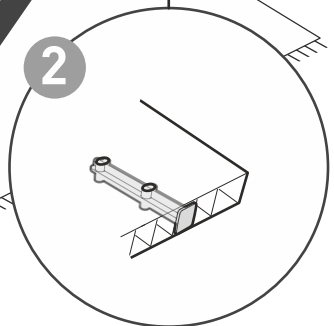
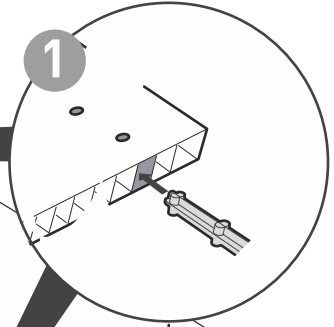
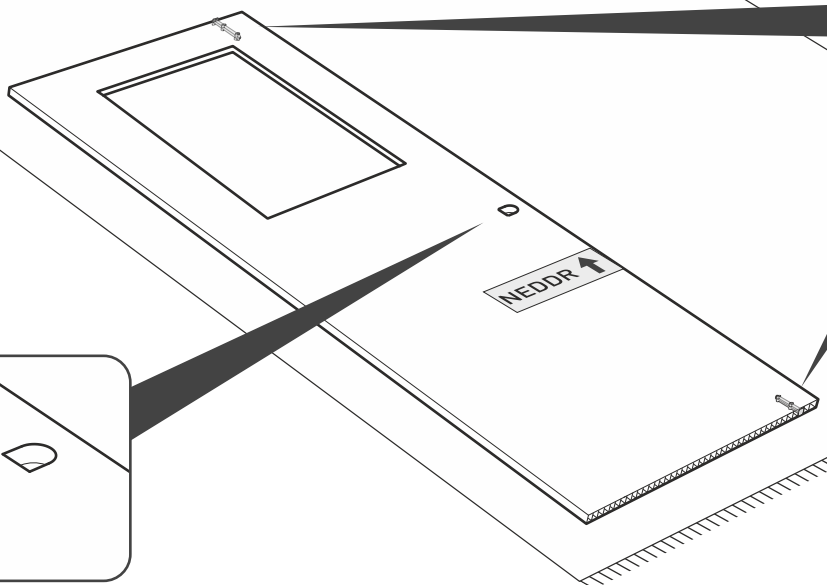
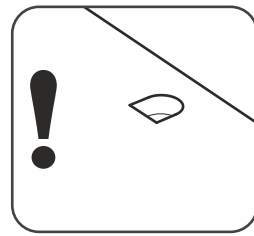
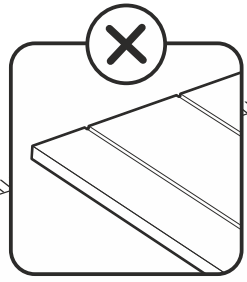
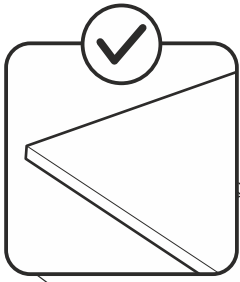
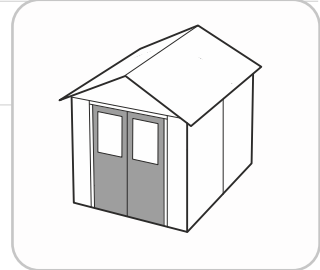

64



NEDDR (x1)



NEDDL (x1)

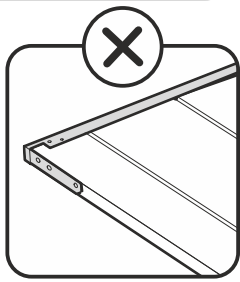
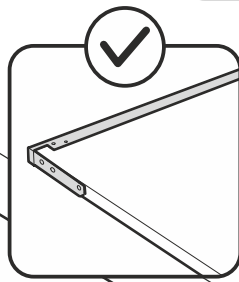
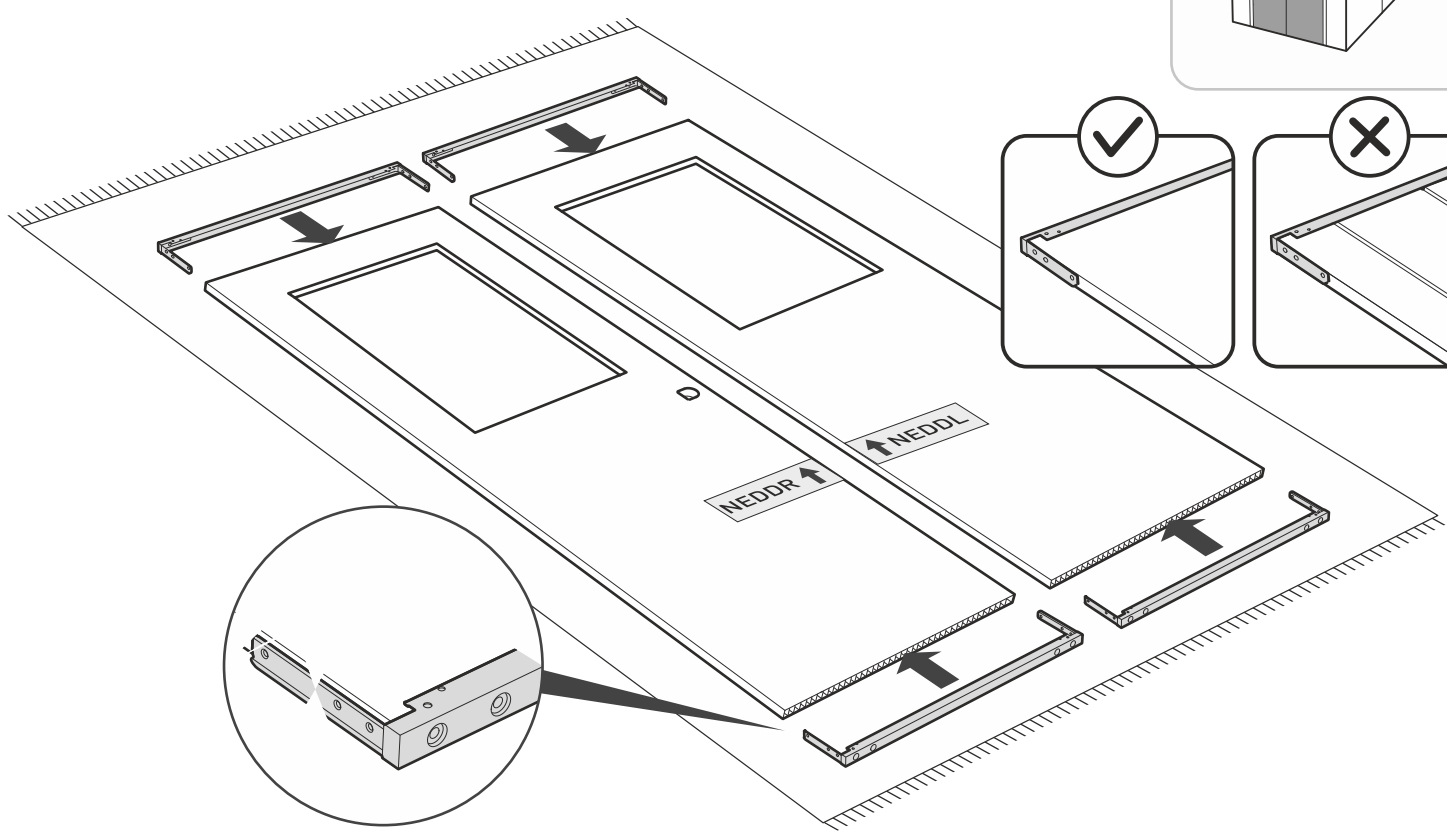
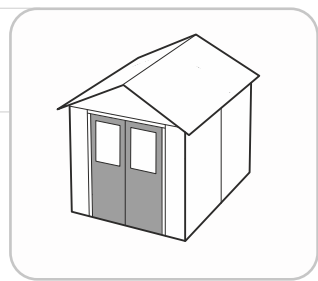

65

NEDSO (x2)

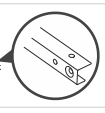

NEDSI (x1)

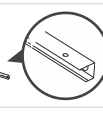

NEDSW (x1)

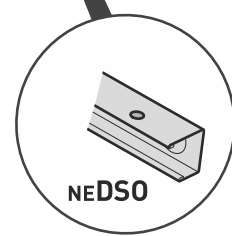
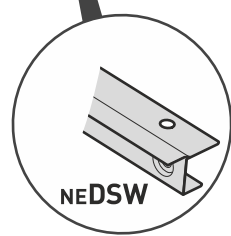
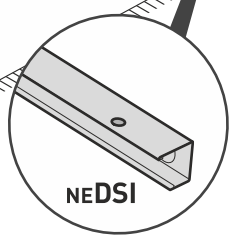
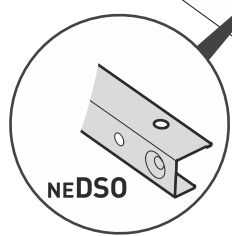
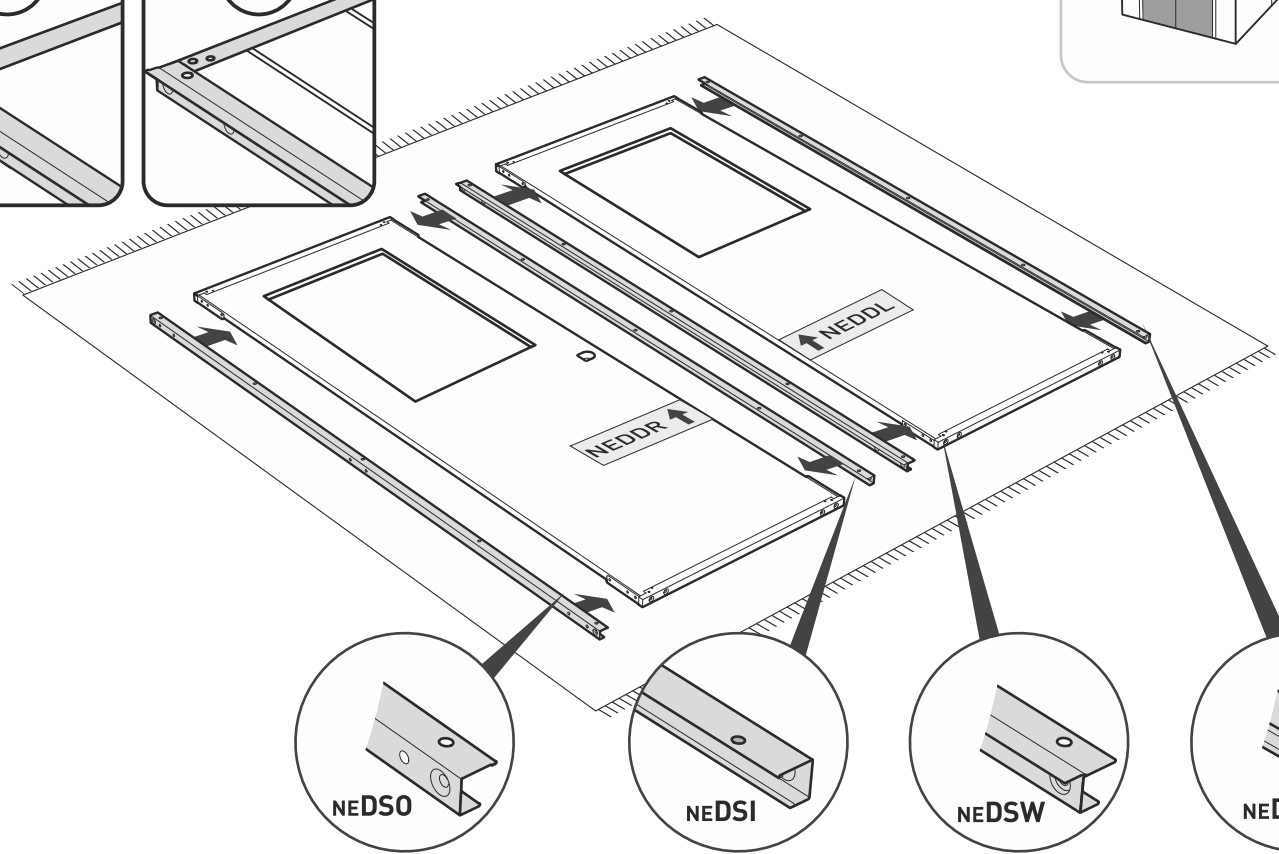
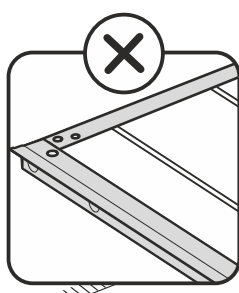
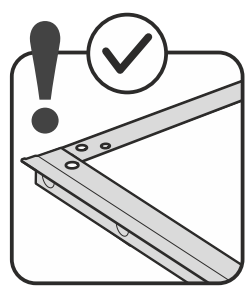
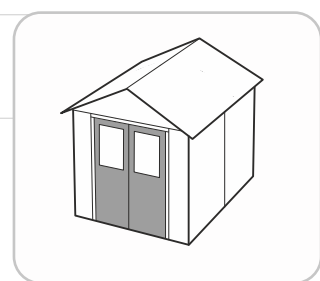
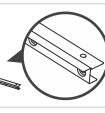

66

sc15 (x12)

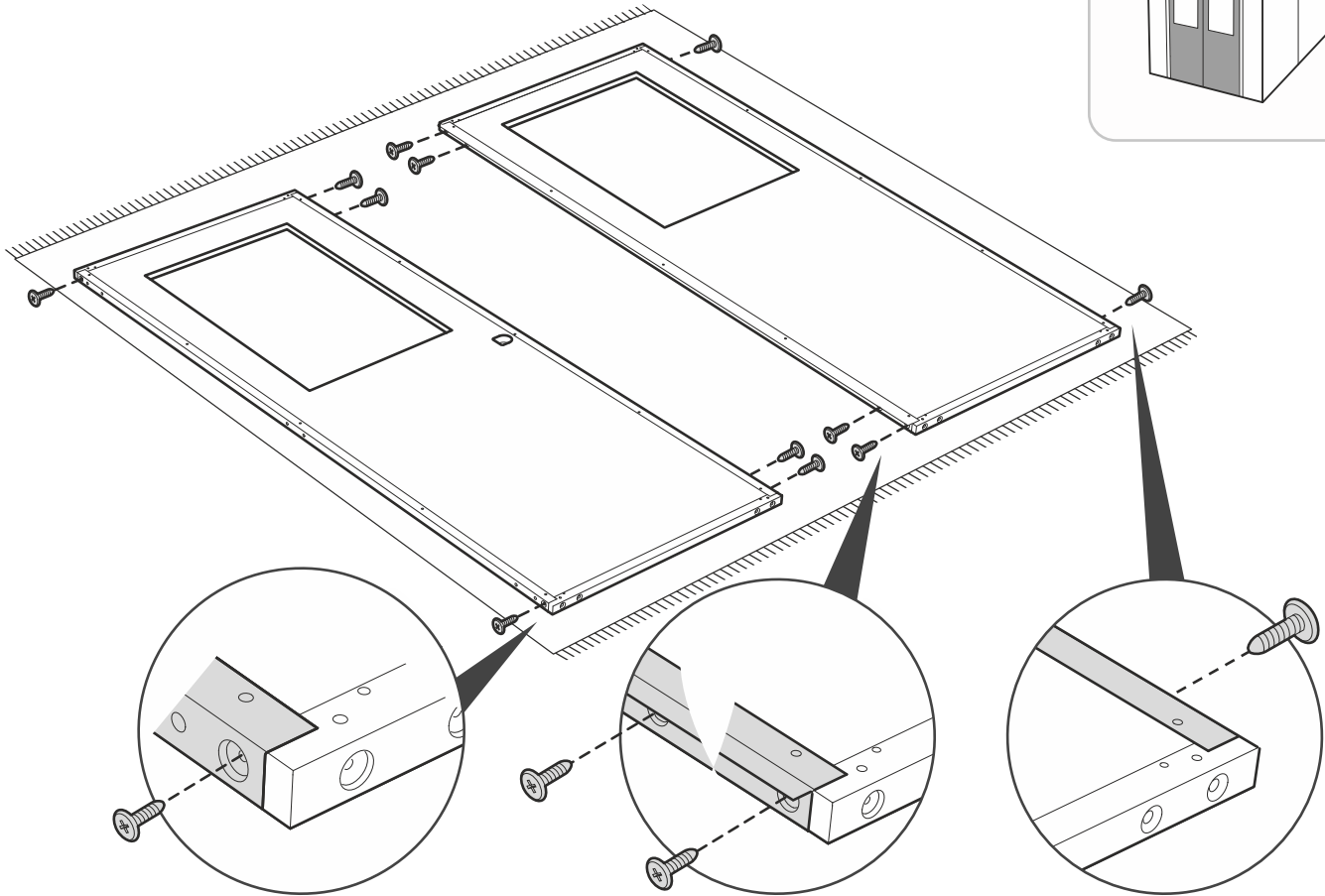
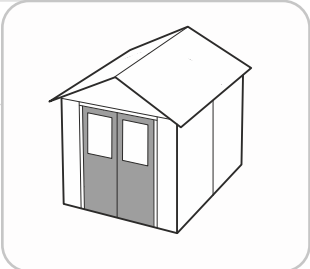

67

NUHG (x2)

NUHH (x2)

sc15 (x4)

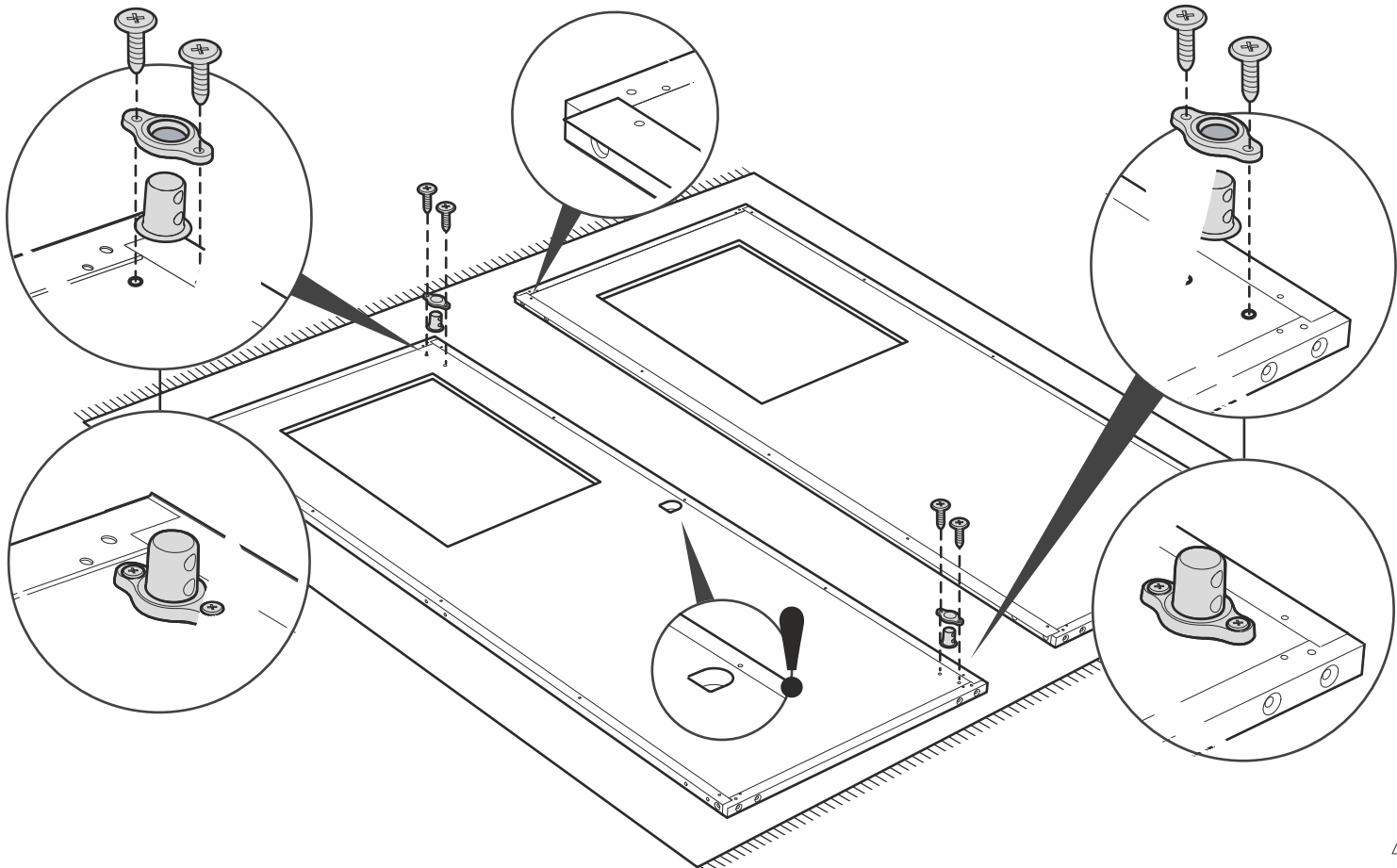

68

!  s13b (x28)

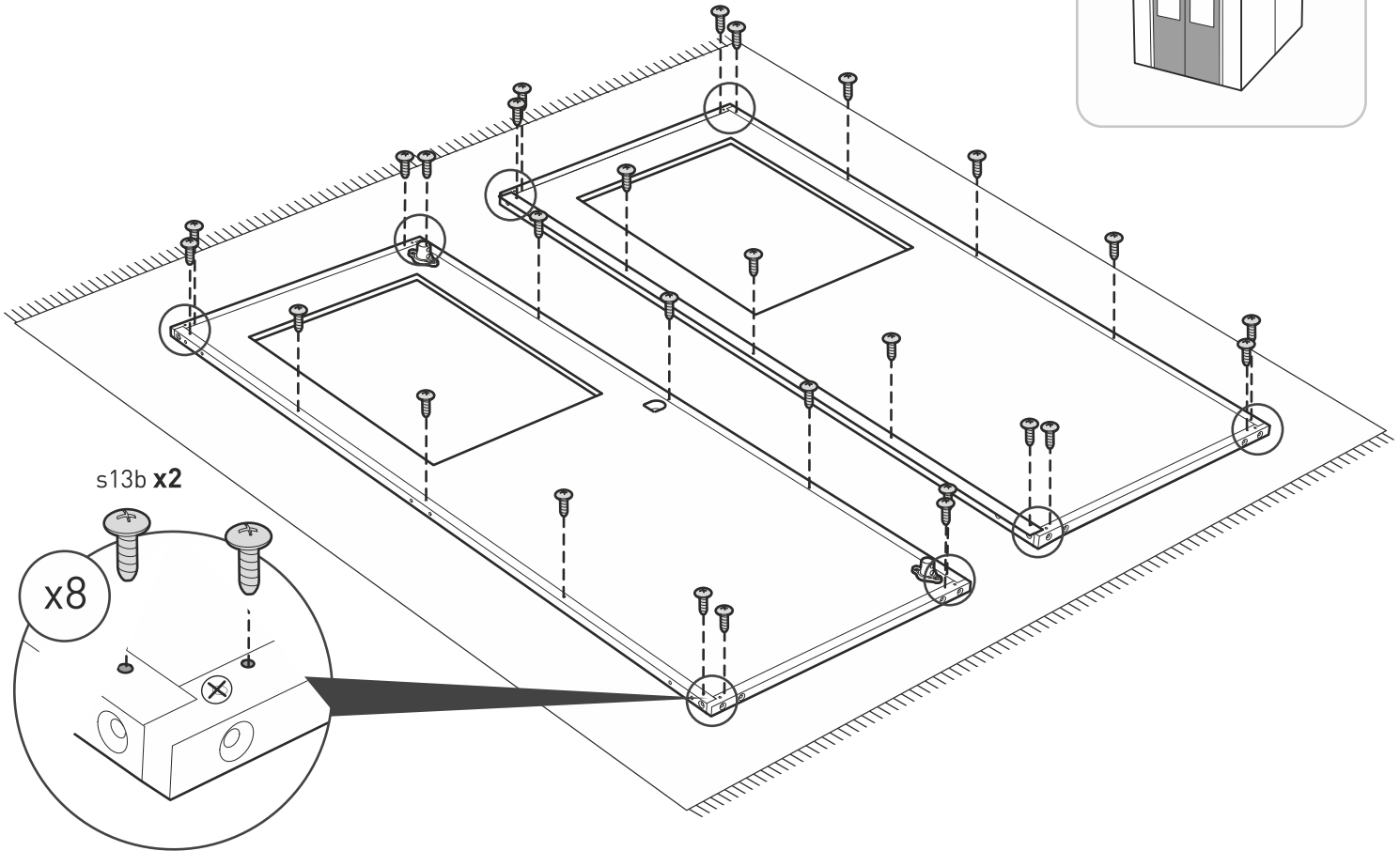
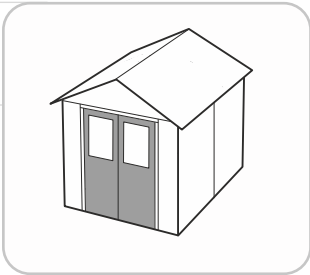

69

 NEDH (x6)

 sc15 (x12)

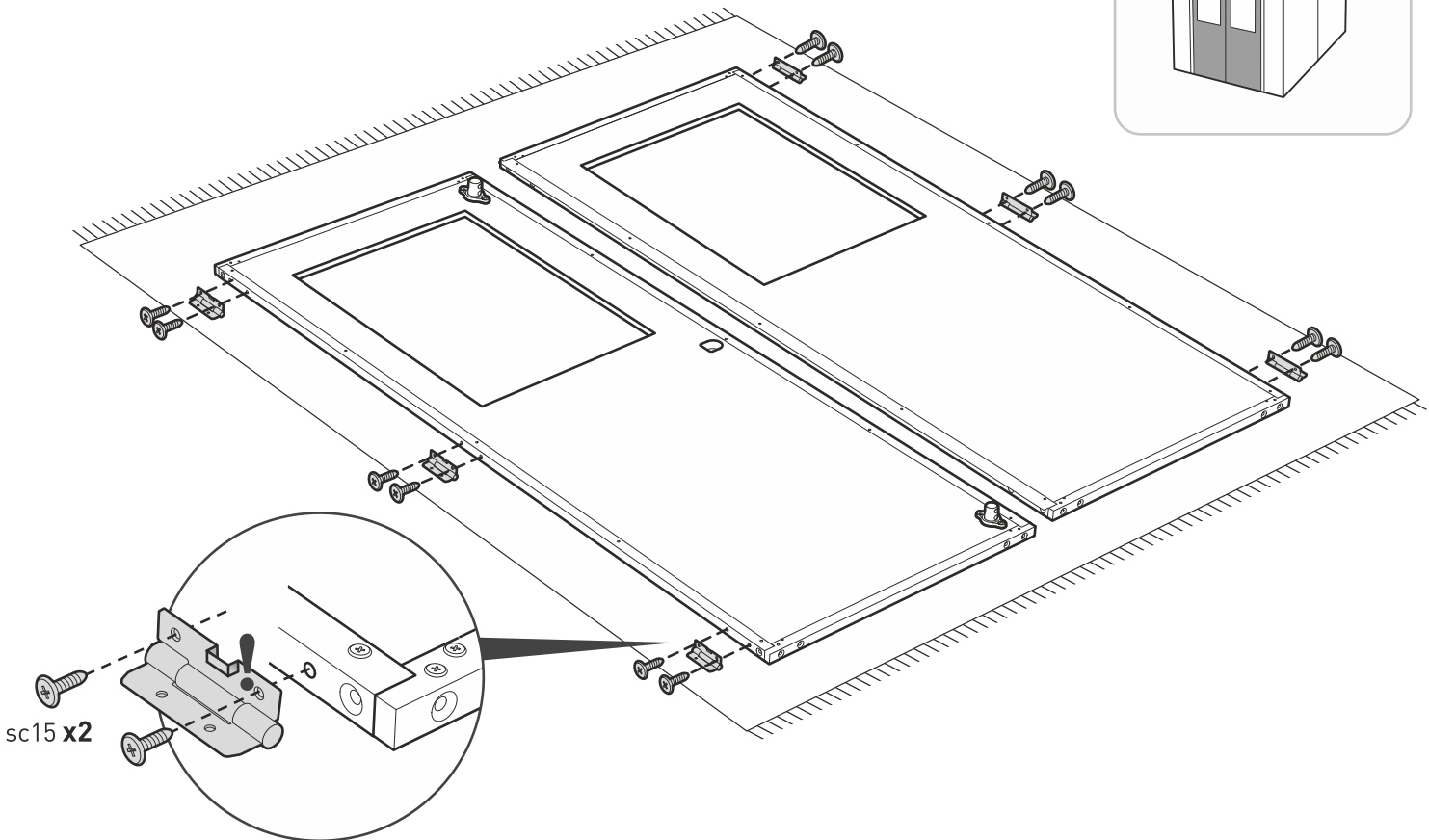
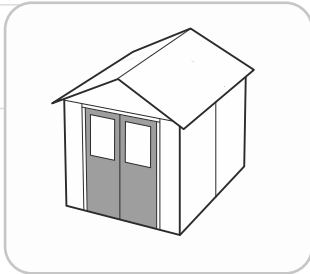

WINDOW ASSEMBLY | MONTAGE DE LA FENÊTRE | VENTANA DEL TECHO | FENSTERHMONTAGE |  
RAAMMONTAGE | MONTAGGIO DE LA FINESTRA | ABLAK ÖSSZESZERELÉS

70



smWF (x2)



smWG (x4)

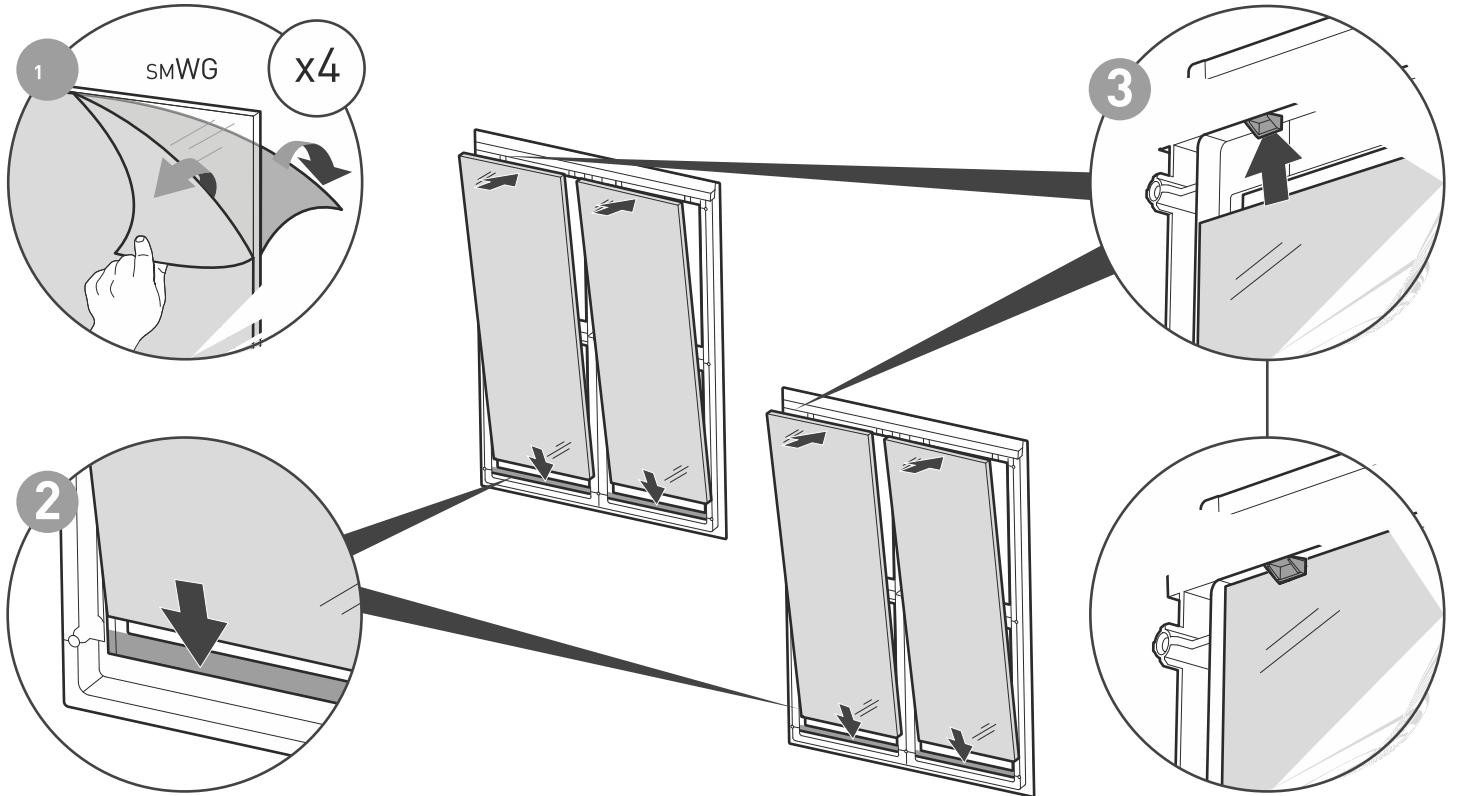

71

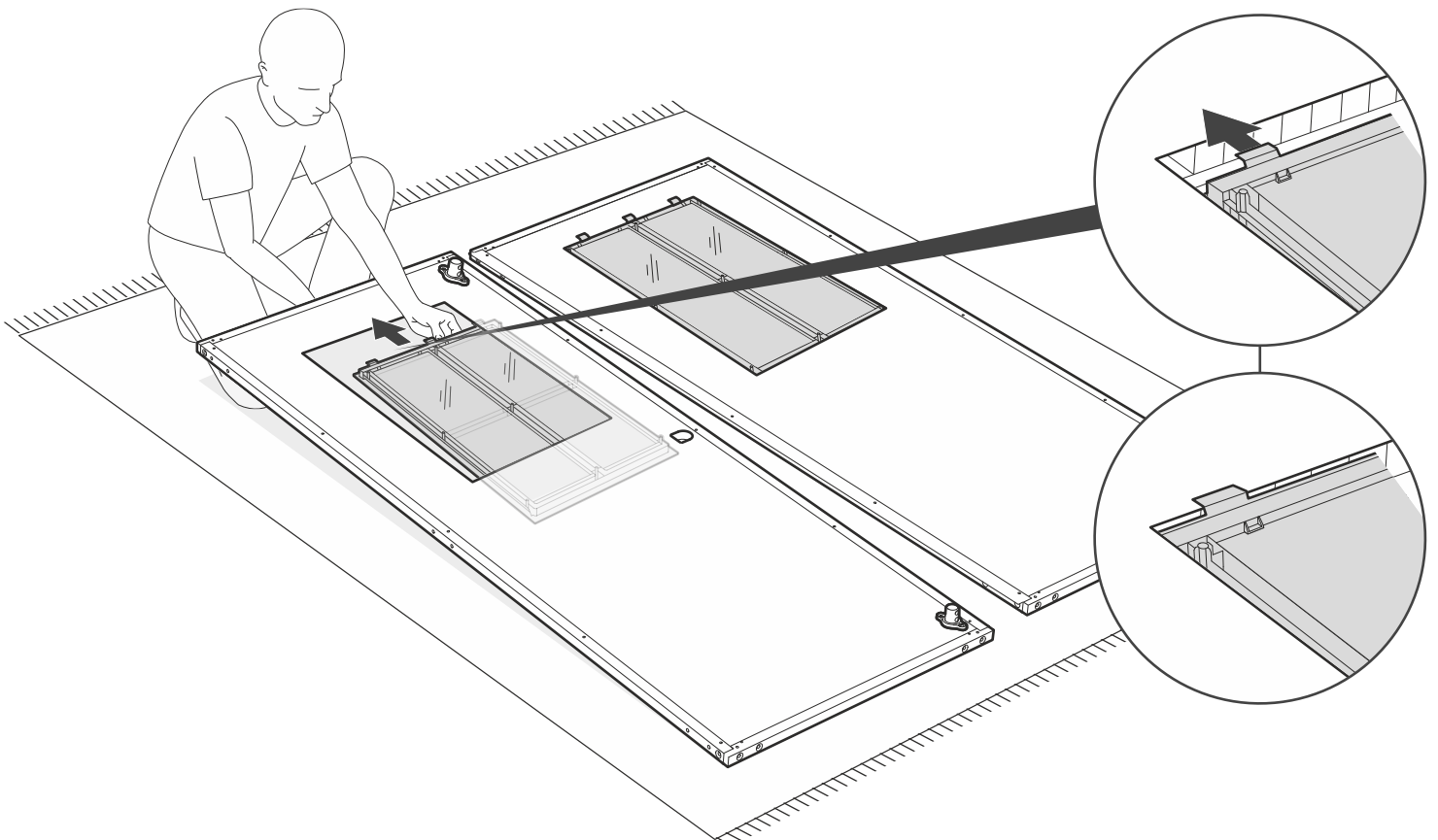



moWB (x2)



sc15 (x18)

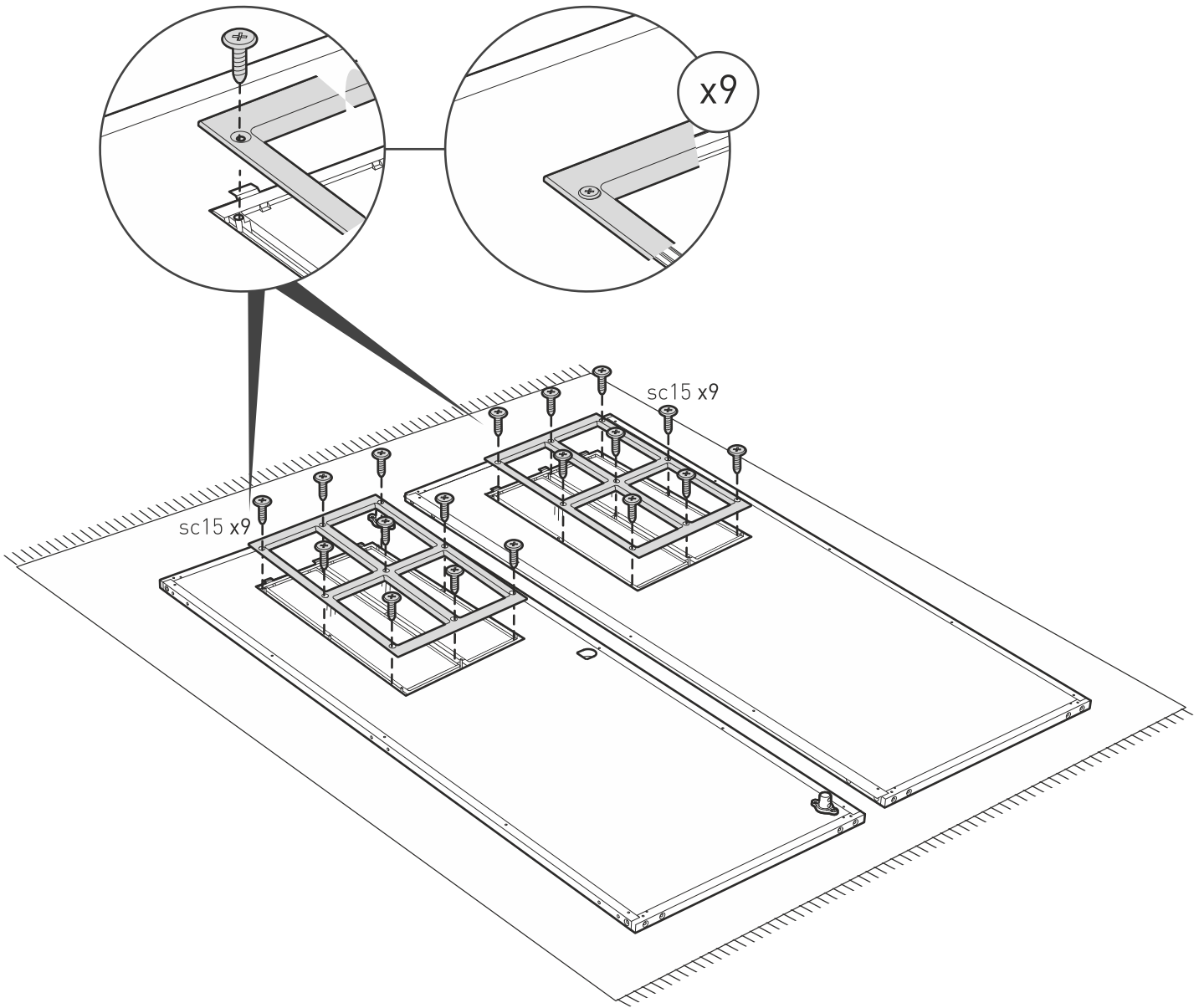

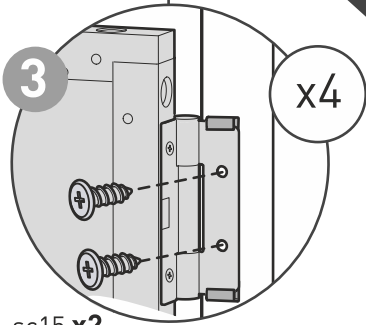
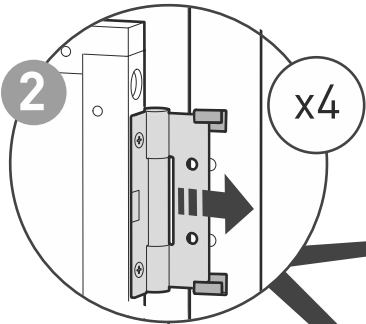
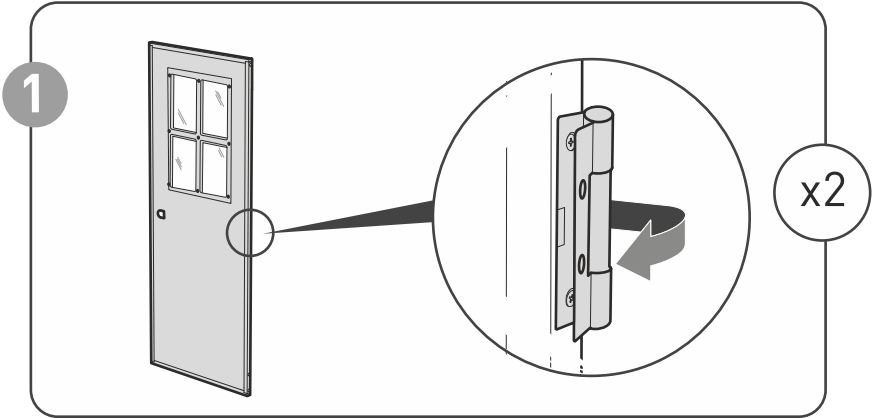
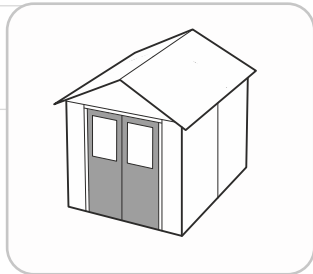

sc15 x2

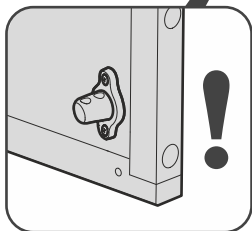
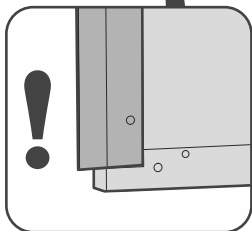
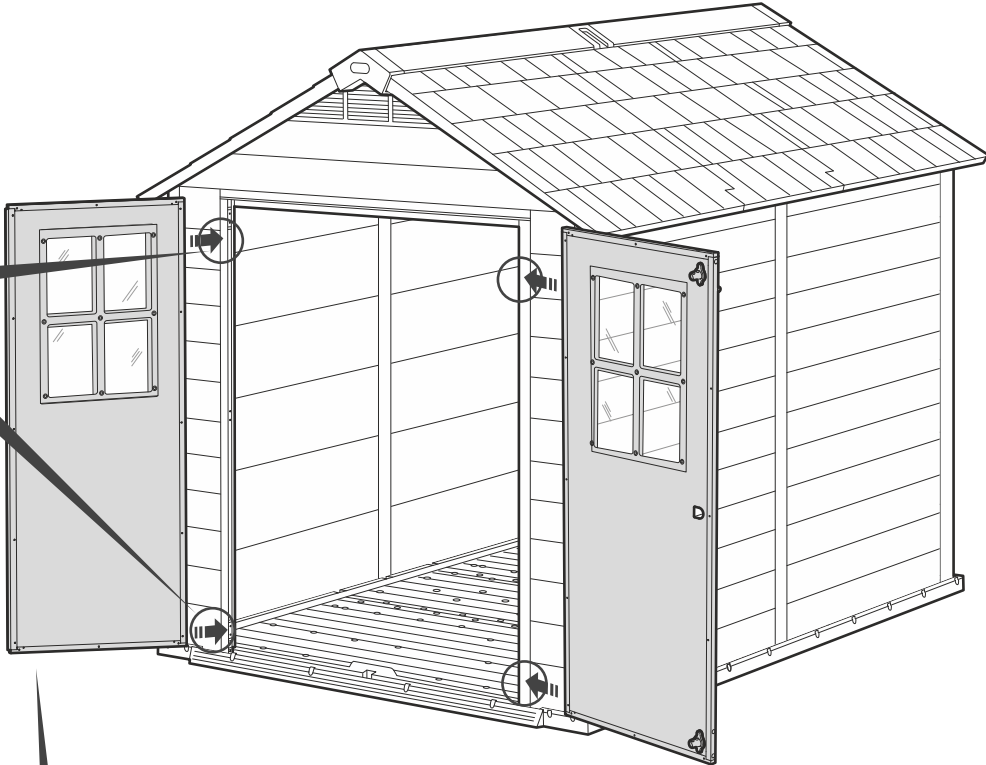

74

 sc15 (x4)

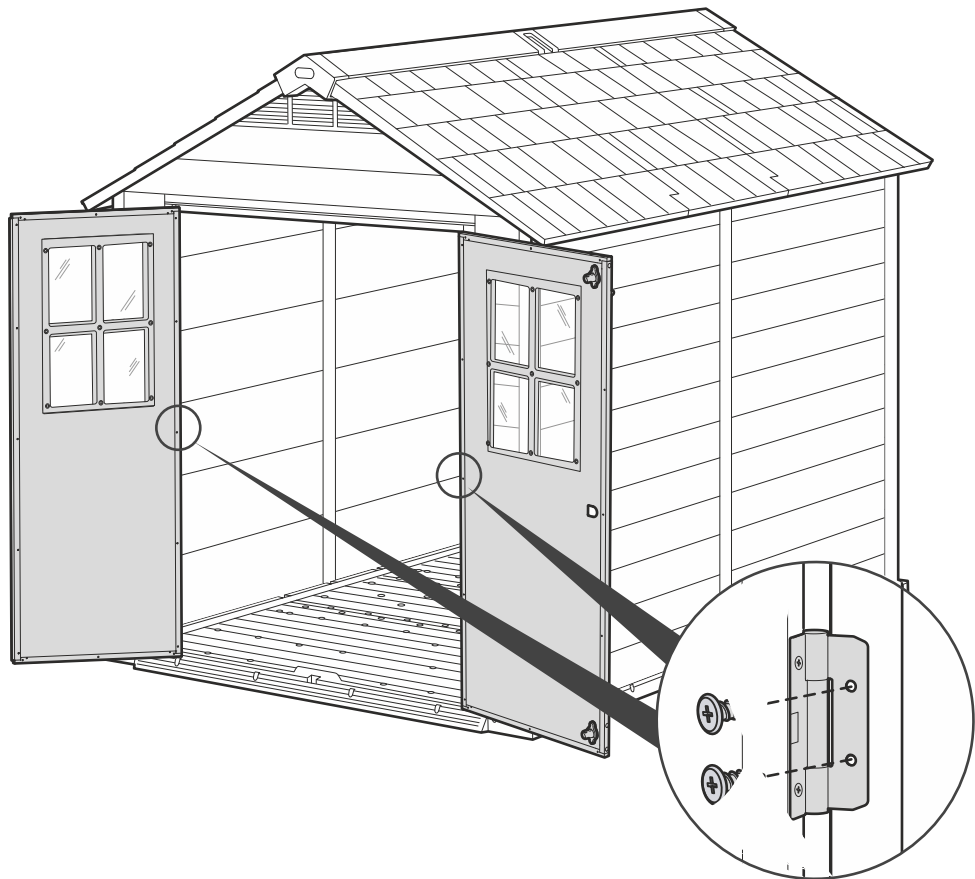
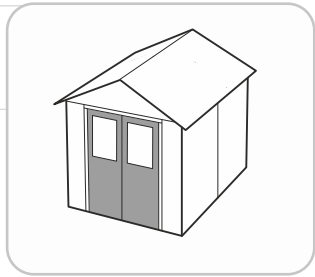

sc15 x2

75

 NUHB (x1)

 NUHA (x1)

 NUHC (x1)

 NUHD (x1)

 sc8 (x1)

 scn8 (x1)

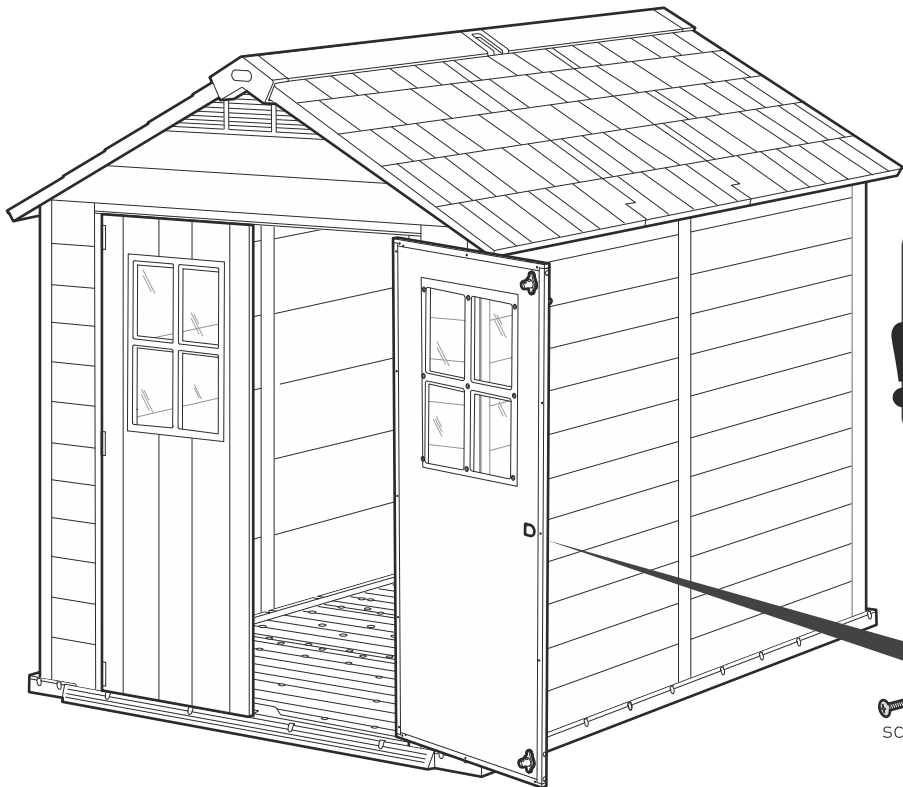
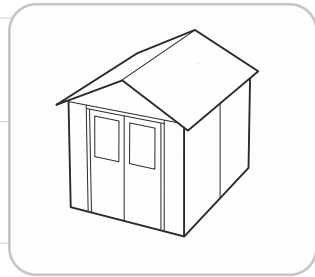

sc8



76



NUHE (x1)



NEMB (x2)



sc15 (x2)

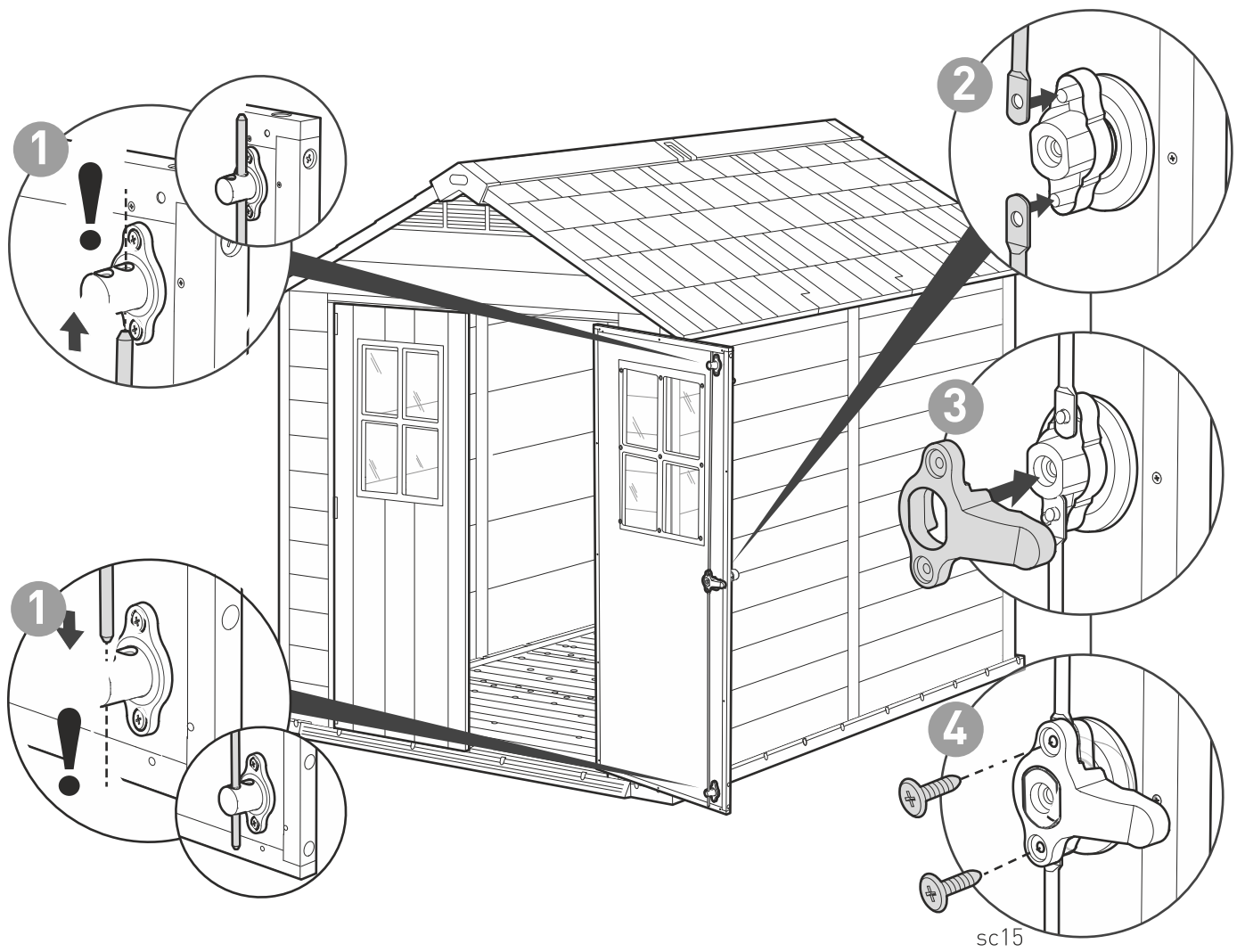
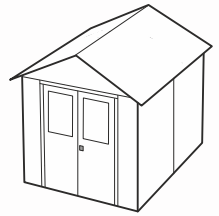

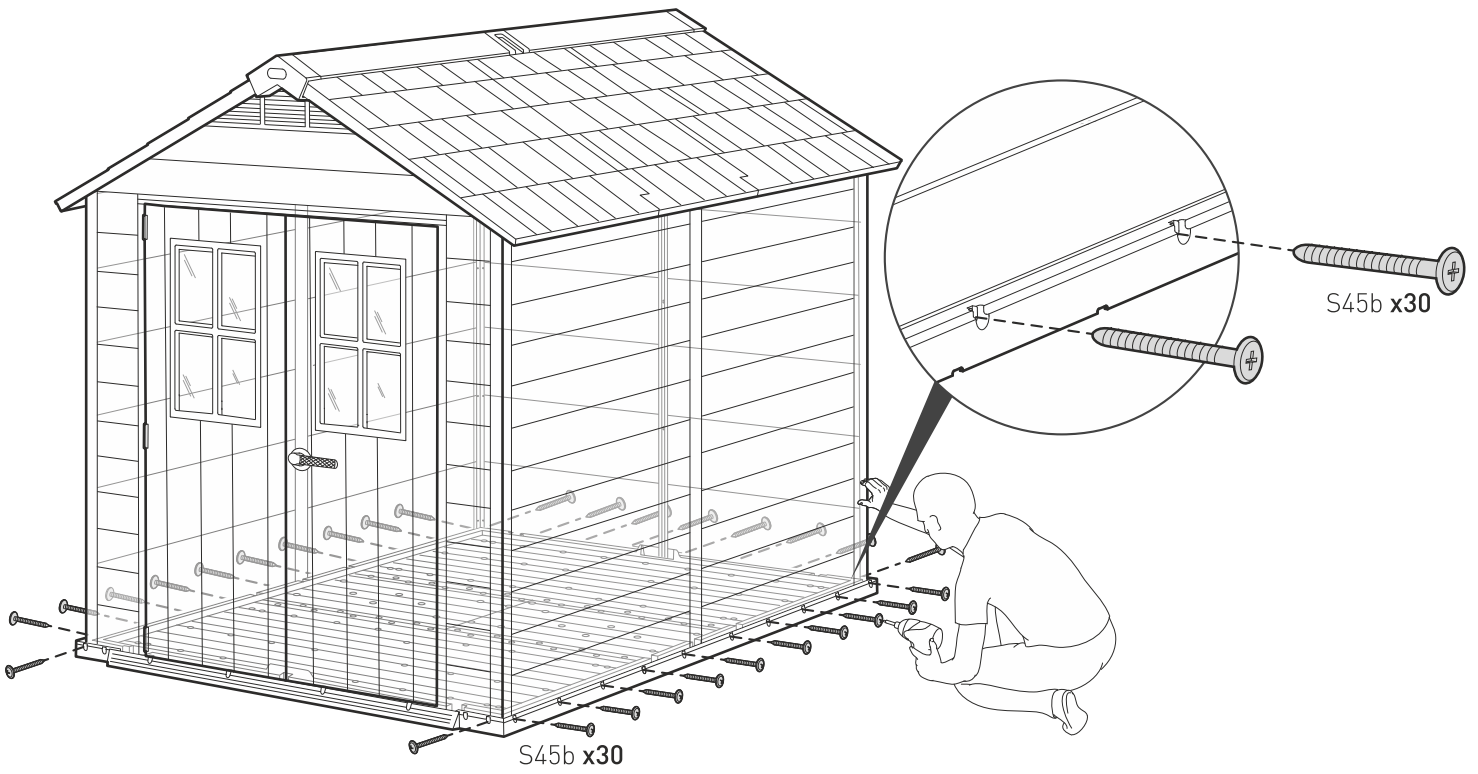
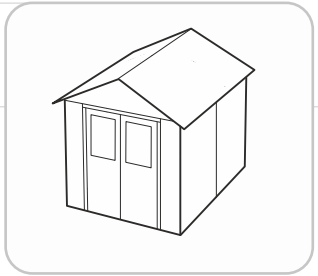

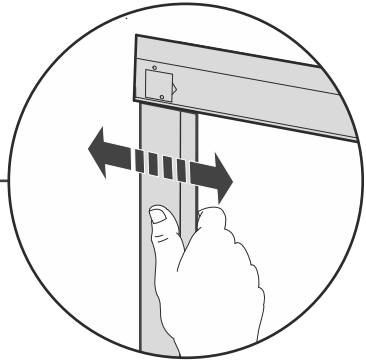
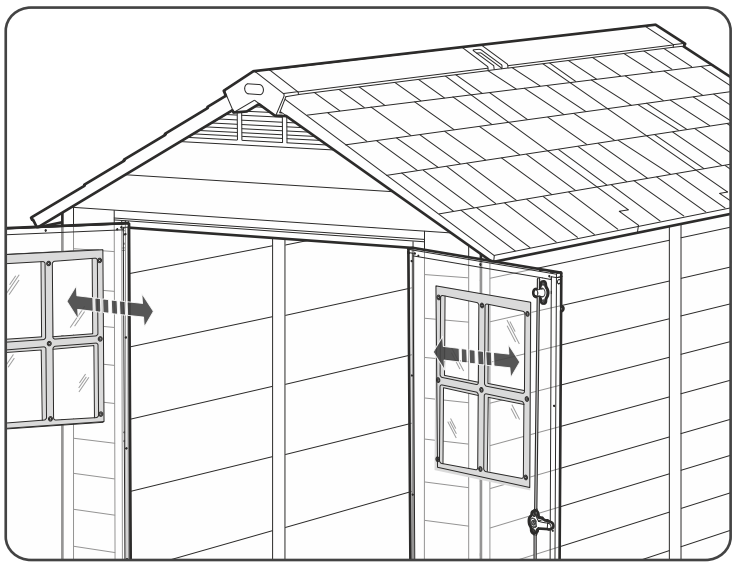
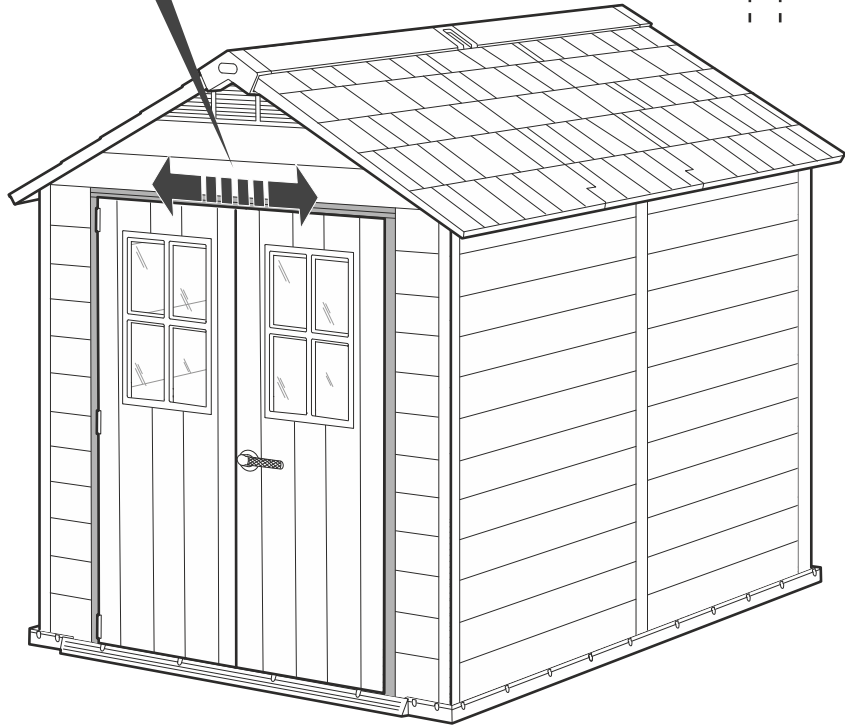
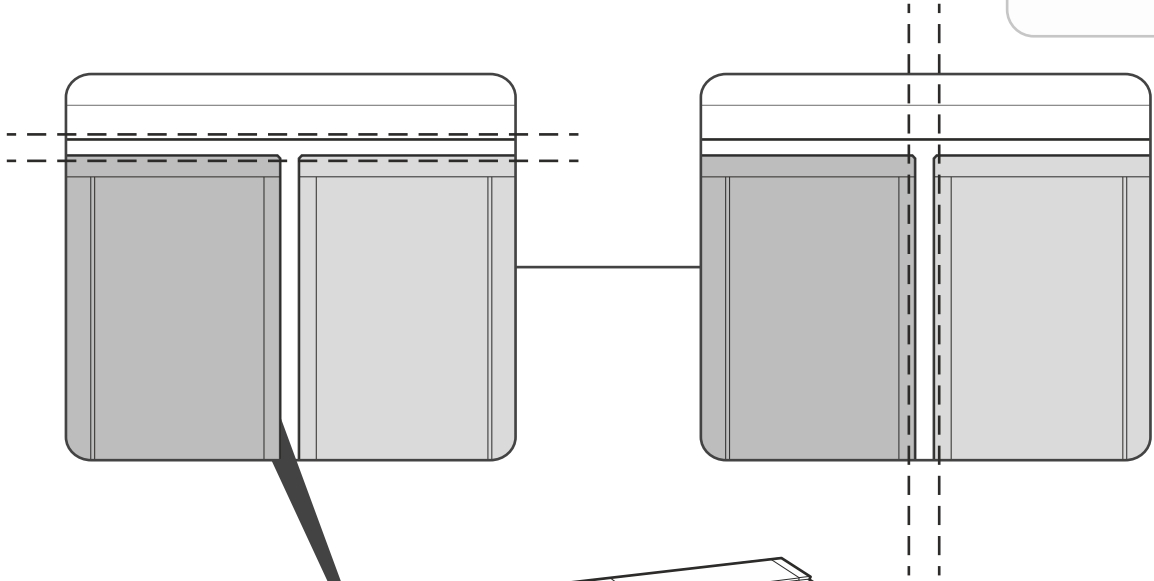
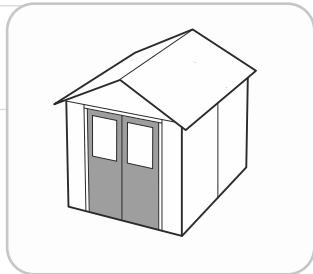

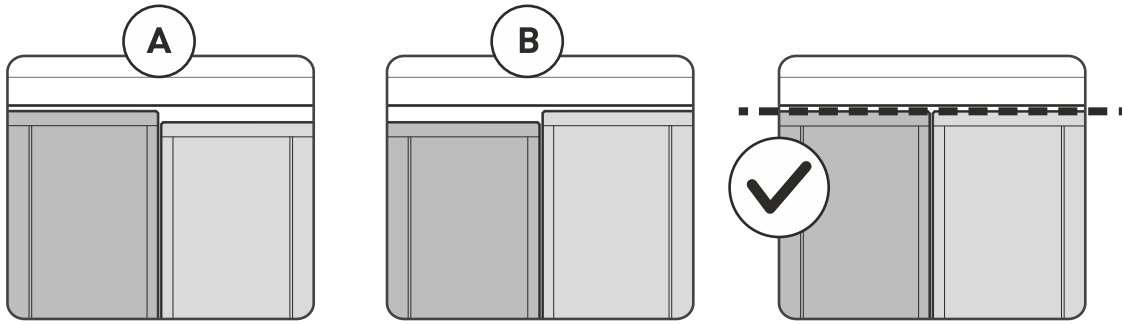
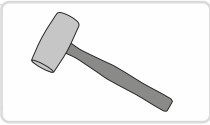

If you find that the shed is not level, use shims on either side of the shed or door | Si vous trouvez que votre abri n'est pas de niveau, mettez des cales sur chaque côté ou au niveau de la porte | Si usted encuentra que el cobertizo no está nivelado, utilice cuñas en ambos lados del cobertizo o en la puerta

Tools and accessories not included | Outils et accessoires non inclus | Herramientas y accesorios no incluidos | Werkzeuge und Zubehör nicht im Lieferumfang | Exclusief gereedschap en accessoires | Utensili e accessori non inclusi | Ferramentas e acessórios não incluídos

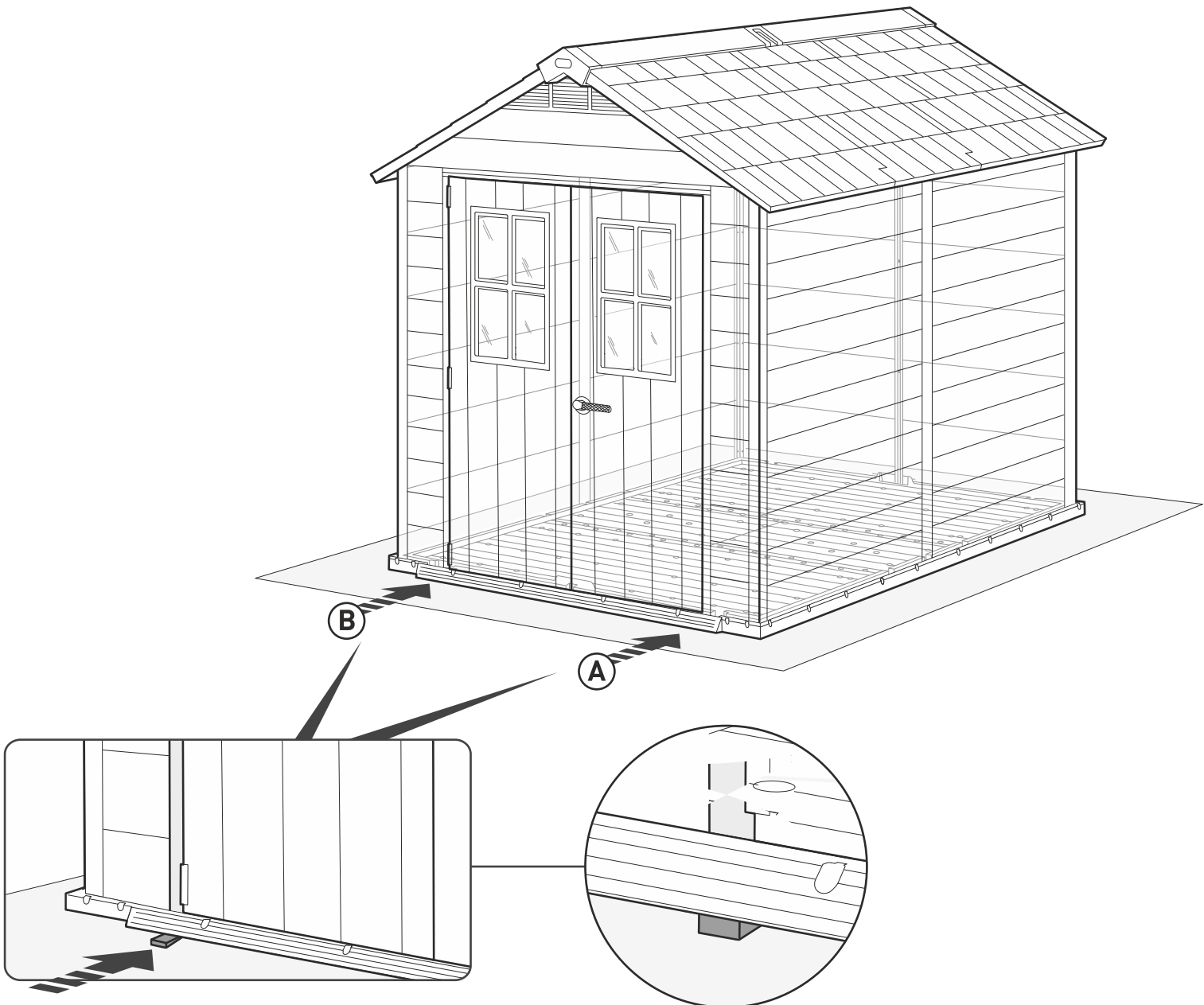

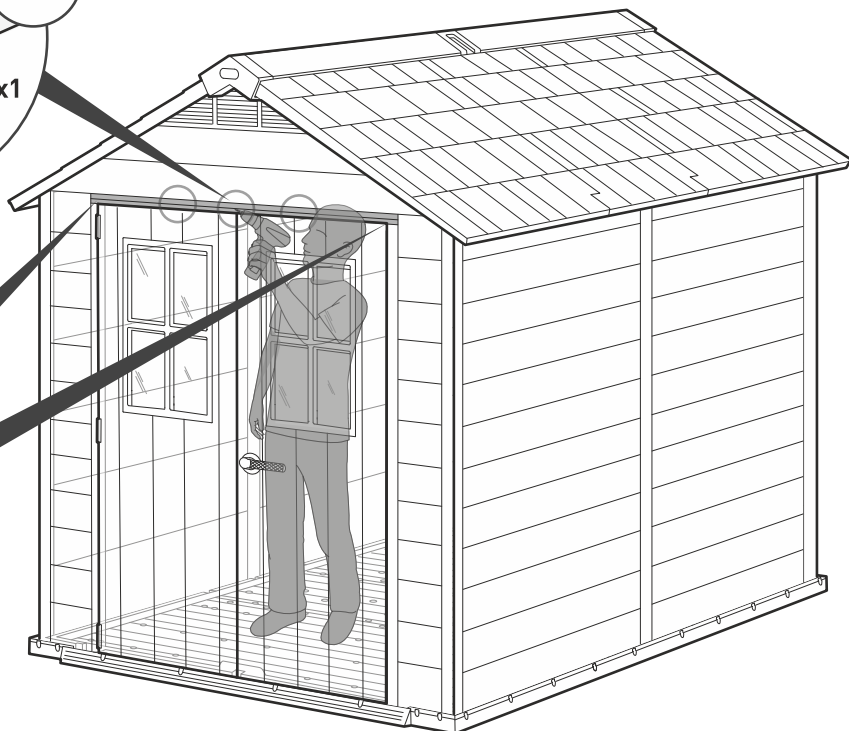
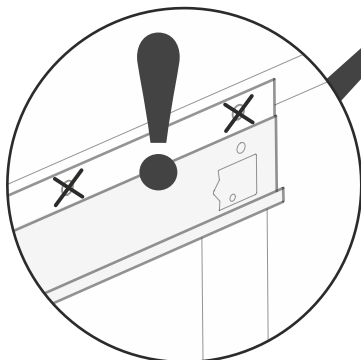
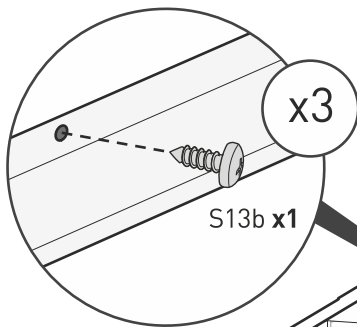
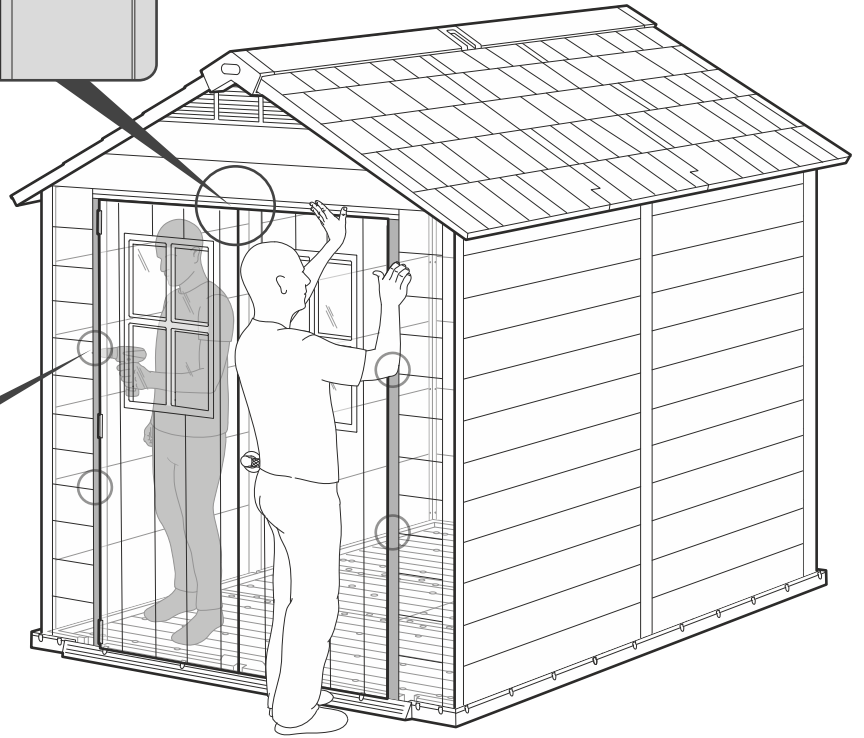
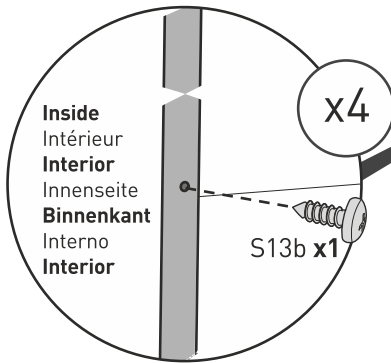
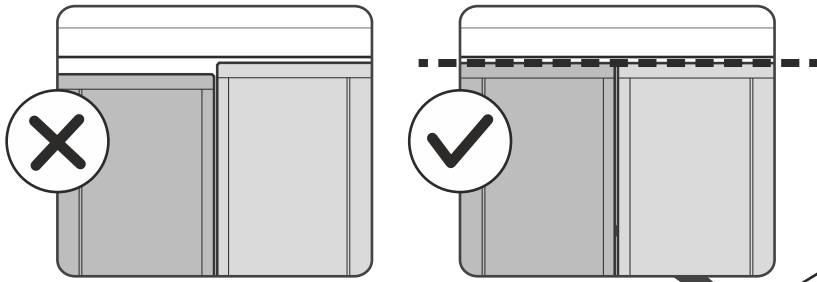
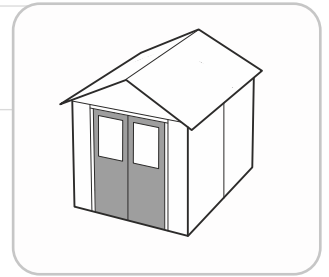

80

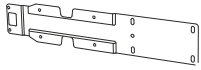

NETPR (x2)

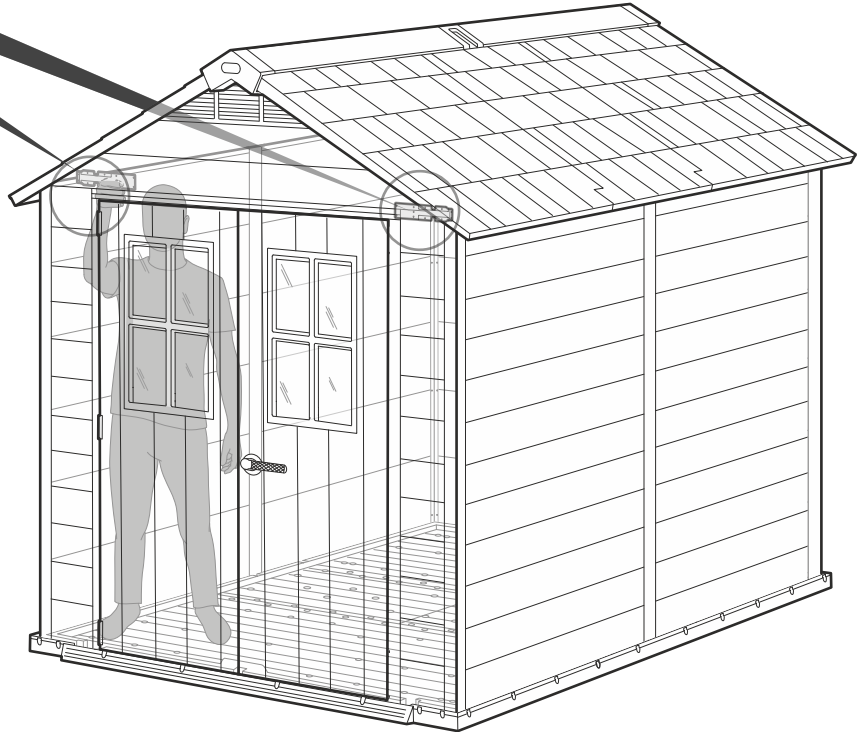
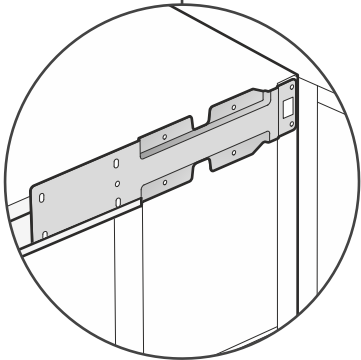
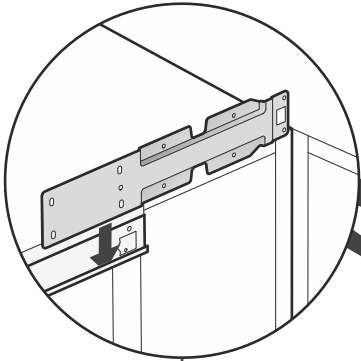
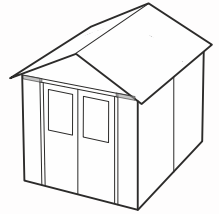

81

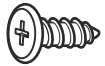

sc15 (x6)

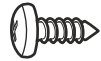

s13b (x12)

No pre-drilled holes | Pas sin agujeros pretaladrados |  
 Ohne vorgebohrte Löcher | Geen voorgeboorde gaten | Buchi preforati non  
 presenti | Nincsenek előre kifúrt lyukak

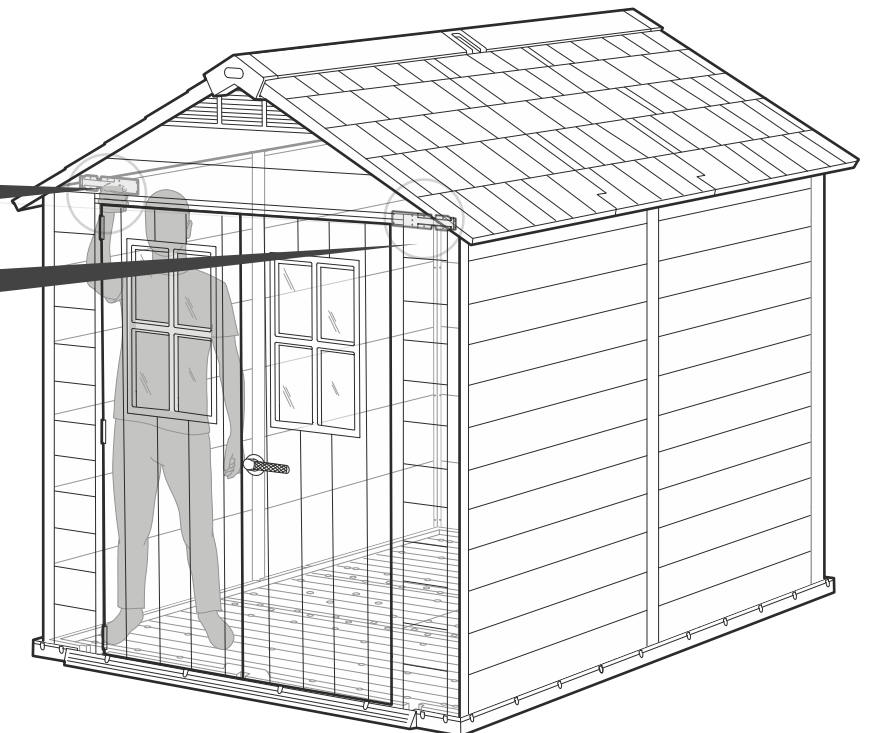
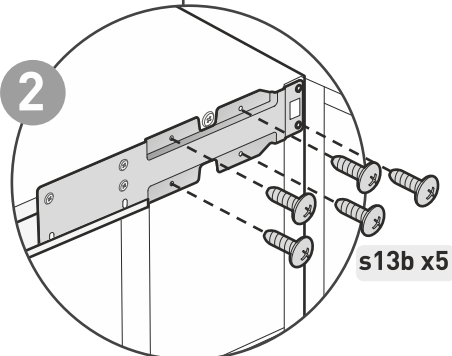
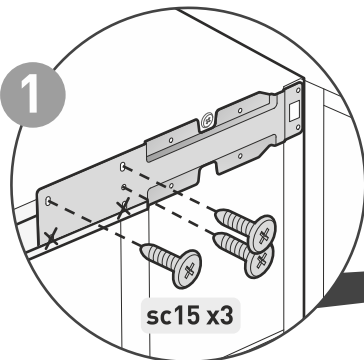
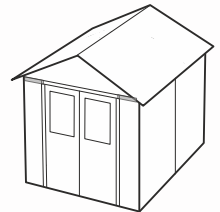



s13b (x20)

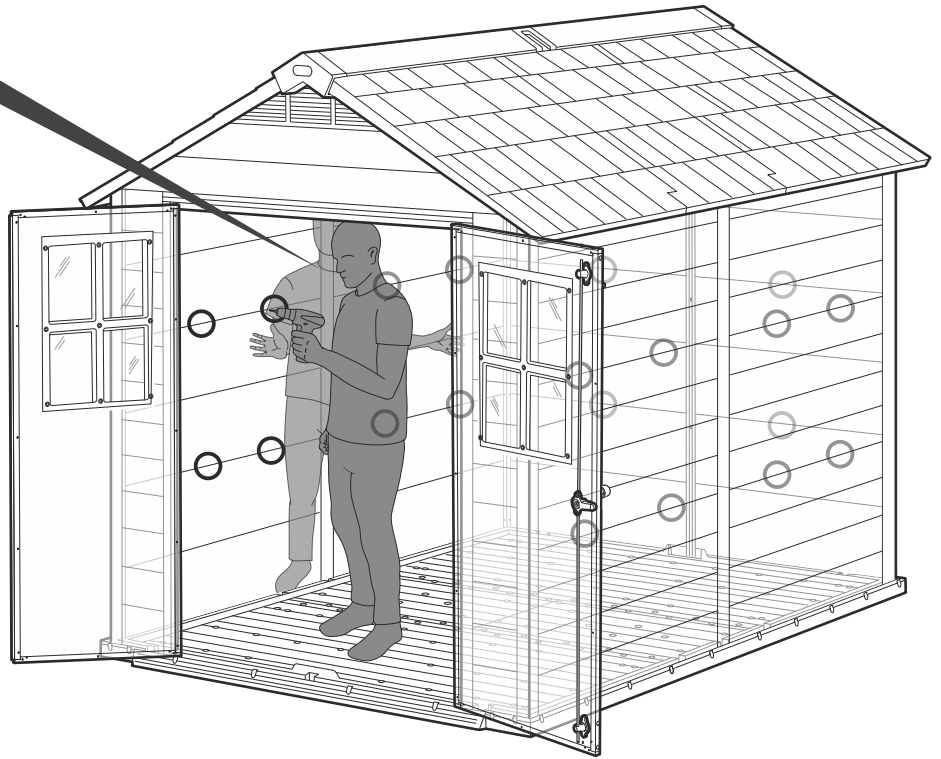
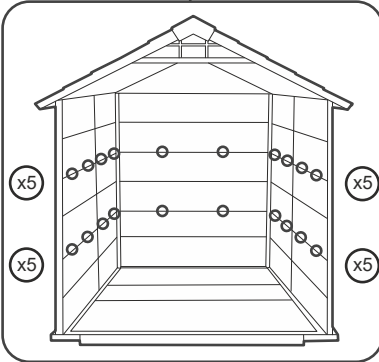
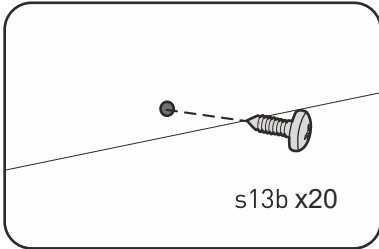
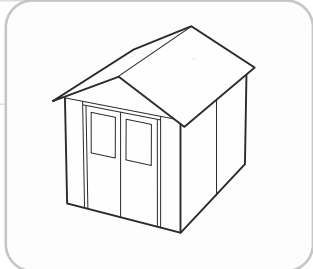

### SECURING THE SHED TO A FOUNDATION

Affix the shed to the foundation by drilling holes in the shed floor at the pre-marked locations and screwing it into the foundation using appropriate screws (screws not included).

### FIXER L'ABRI SUR UNE FONDATION

Fixez l'abri à la fondation en perçant des trous dans le sol aux endroits pré-marqués et en insérant des vis adéquates dans la fondation (vis non fournies).

### ASEGURAR EL COBERTIZO A UN CIMIENTO

Fije el cobertizo a los cimientos perforando agujeros en el suelo del cobertizo en los lugares previamente marcados y atorníllelo a los cimientos utilizando los tornillos adecuados (los tornillos no están incluidos).

### ABSICHERN DES SCHUPPENS AN EIN FUNDAMENT

Bringen Sie den Schuppen auf dem Fundament an, indem Sie an den Markierungen Löcher in den Schuppenboden bohren und diesen mit passenden Schrauben auf dem Fundament festschrauben (Schrauben nicht enthalten).

### HET SCHUURTJE OP HET FUNDAMENT VASTZETTEN

Bevestig het schuurtje aan de fundering door op de aangegeven plaatsen gaten te boren in de vloer van het schuurtje en het schuurtje aan de fundering te schroeven met behulp van passende schroeven (schroeven niet inbegrepen).

### ASSICURARE LA COPERTURA ALLE FONDAMENTA

Fissa il deposito attrezzi alle fondamenta facendo dei fori nel pavimento nelle posizioni pre-segnalate ed avvitandolo alle fondamenta utilizzando apposite viti (viti non incluse).

### RÖGZÍTSE A HÁZAT AZ ALAPHOZ

Rögzítse a házat az alaphoz úgy, hogy lyukakat fúr a talajba az előzőleg megjelölt helyeken, és megfelelő csavarokkal csavarja rá (a csavarokat nem tartalmazza).

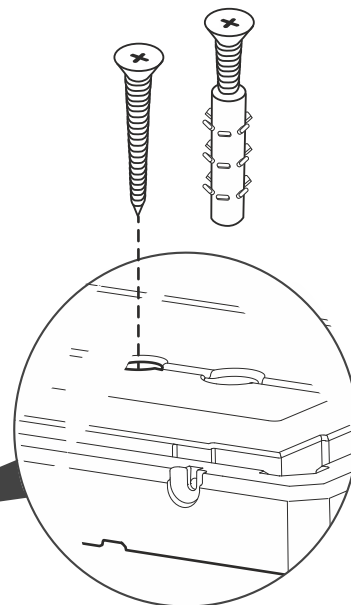
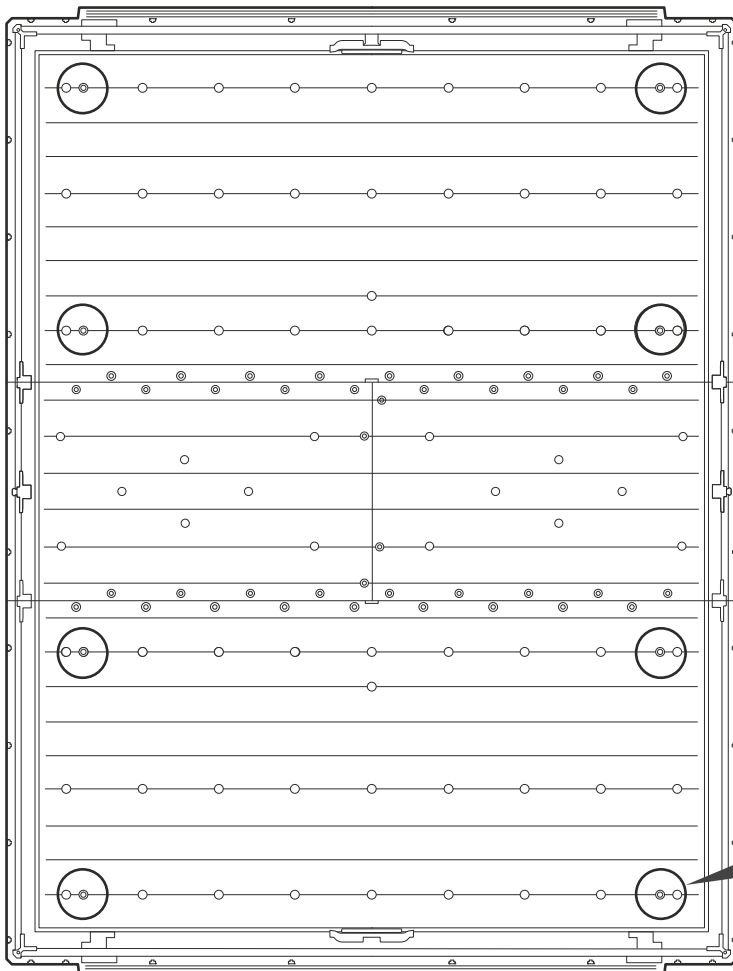
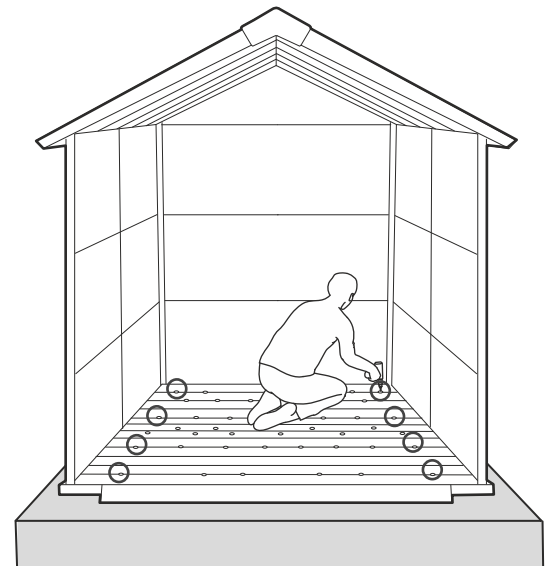



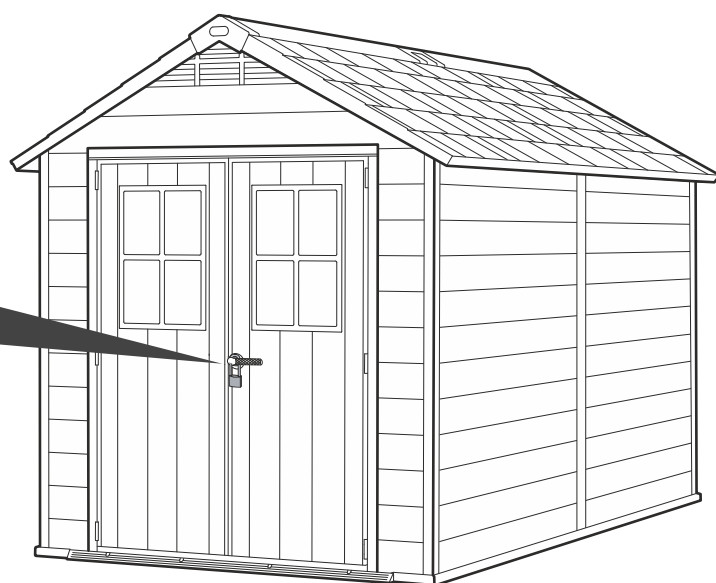
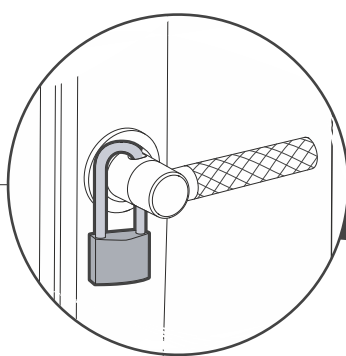
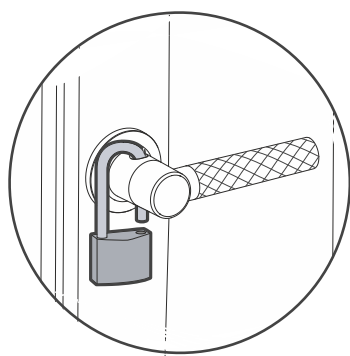
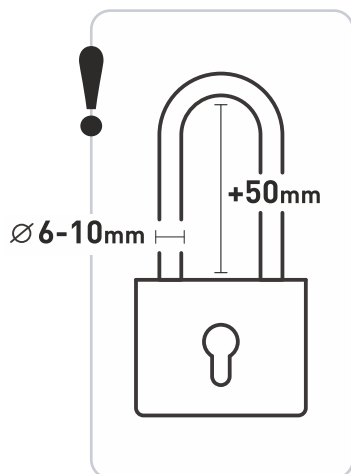
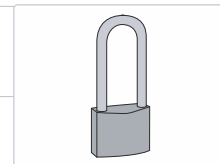

---

## CARE AND SAFETY GUIDELINES

---

- The shed is intended for storage purposes only. It is not designed for habitation.
- It is strongly recommended to secure the shed to an immovable object or anchor to the ground by drilling holes in the shed floor (at the pre-marked locations) and inserting proper screws into the ground (screws are not included).
- Do not attempt assembly on windy or cold days.
- Periodically check the shed to ensure that it is stable and that the site is level.
- Be careful when handling parts with steel edges.
- When assembling or handling the shed, use only those tools listed in the user manual.
- Avoid using a lawnmower or mechanical scythe near the shed.
- Wear safety goggles and always follow the manufacturer's instructions when using power tools.
- Wash the shed with a garden hose or a mild detergent solution. Do not use a stiff brush or abrasive cleaners, including degreasers and oil- or acetone-based cleaning materials, as these may stain or damage the shed.
- Do not store hot items, such as recently used grills and blowtorches, and volatile chemicals in the shed.
- Avoid placing heavy items against the walls, as this may cause distortion.
- Keep the roof clear of accumulated snow and leaves. Large amounts of snow on the roof can damage the shed, making it unsafe to enter.
- Wind direction is an important factor to consider when determining the location of the shed. Reduce exposure to the wind, in general, and of the door side in particular. Keep doors closed and locked when the shed is not in use to prevent wind damage.
- Do not stand on the roof.
- Consult your local authorities to check if permits are required to erect the shed.

---

## INSTRUCTIONS DE SÉCURITÉ ET D'ENTRETIEN

---

- L'abri a été conçu uniquement à des fins de stockage. Il n'a pas été conçu à des fins d'habitation.
- Il est fortement recommandé de sécuriser l'abri à un objet inamovible ou de le fixer au sol en creusant des trous dans le sol de l'abri (aux emplacements marqués) et d'insérer les vis adaptées dans le sol (vis non incluses).
- N'essayez pas de réaliser le montage par jour venteux ou froid.
- Vérifiez de temps en temps la tenue de l'abri afin de garantir sa stabilité et la mise à niveau du site, sur lequel il est posé.
- Manipulez les pièces présentant des bords en acier avec précaution.
- Lors de l'assemblage ou de la manipulation de l'abri, utilisez seulement les outils listés dans le mode d'emploi.
- Évitez d'utiliser une tondeuse à gazon ou une faux mécanique à proximité de l'abri.
- Portez des lunettes de sécurité et suivez toujours les instructions du fabricant lors de l'utilisation d'outils électriques.
- Lavez l'abri à l'aide d'un tuyau d'arrosage de jardin ou d'un détergent non abrasif. N'utilisez pas une brosse dure ou de nettoyeurs abrasifs, y compris les dégraissants et les solutions de nettoyage à base d'acétone ou d'huile, car ils peuvent tacher ou endommager l'abri.
- Ne stockez pas d'objets chauds, tels qu'un grill ou un chalumeau récemment utilisé, ou des produits chimiques volatiles dans l'abri.
- Évitez de placer des objets lourds contre les murs de votre abri, cela peut entraîner une déformation.
- Entretenez le toit pour éviter l'accumulation de neige ou de feuilles. Une grande quantité de neige sur le toit peut endommager l'abri, rendant périlleux l'accès à l'intérieur.
- La direction du vent est un facteur important à prendre en compte lors du choix de la localisation de l'abri. Réduisez l'exposition au vent, en général, et surtout pour le côté de la porte. Maintenez les portes fermées et verrouillées lorsque l'abri n'est pas utilisé, afin d'éviter tout dégât dû au vent.
- Ne montez pas sur le toit.
- Consultez les autorités de votre localité pour vérifier la nécessité de disposer d'un permis pour ériger l'abri.

---

## ADVERTENCIA SOBRE EL CUIDADO Y LA SEGURIDAD

---

- La cobertizo está diseñada solo para el almacenamiento de productos. No está diseñada para habitar en ella.
- Se recomienda encarecidamente fijar la cobertizo a un objeto inamovible o anclarla al suelo taladrando agujeros en el suelo de la cobertizo (en los lugares premarcadas para ello), e insertando tornillos adecuados en el suelo (los tornillos no están incluidos).
- No intente montarlo en días de viento o cuando haga frío.
- Compruebe la cobertizo periódicamente para asegurarse de que es estable y de que el lugar es uniforme.
- Tenga cuidado al manejar las partes con bordes de acero.
- Al montar o manipular la cobertizo, use solamente las herramientas enumeradas en el manual del usuario.
- Evite usar un cortacésped o un cortacésped cerca de la cobertizo.
- Lleve gafas de seguridad y siga siempre las instrucciones del fabricante al utilizar herramientas eléctricas.
- Lave la cobertizo con una manguera de jardín o con un detergente suave.
- No utilice un cepillo rígido ni limpiadores abrasivos, incluyendo desengrasantes y materiales de limpieza basados en petróleo o acetona, ya que todos ellos pueden manchar o dañar la cobertizo.
- No guarde objetos calientes, como sopletes usados recientemente, ni elementos químicos volátiles.
- Evite situar objetos pesados contra las paredes, ya que esto puede causar deformación.
- Mantenga el techo limpio de nieve y hojas acumuladas. Una gran cantidad de nieve en el tejado puede dañar el cobertizo, haciendo que sea inseguro entrar.
- La dirección del viento es un factor importante a tener en cuenta al determinar la ubicación del cobertizo. Reduzca la exposición al viento en general y al lateral de la puerta en particular. Mantenga las puertas cerradas y bloqueadas cuando no utilice el cobertizo para evitar daños del viento.
- No se ponga de pie sobre el techo.
- Consulte con sus autoridades locales y son necesarios permisos para levantar el cobertizo.

---

## PFLEGE- UND SICHERHEITSHINWEISE

---

- Der Gartenschuppen dient einzig und allein der Lagerung von Gegenständen. Der Schuppen ist nicht für Wohnzwecke ausgelegt.
- Es wird dringend empfohlen, den Schuppen an einem unbeweglichen Gegenstand zu befestigen oder Mithilfe von Löchern im Schuppenboden im Boden zu verankern (die Bohrungen müssen an den vormarkierten Stellen erfolgen), wobei geeignete Schrauben zu verwenden sind (Schrauben sind nicht im Lieferumfang enthalten).
- Führen Sie den Aufbau nicht an windigen oder kalten Tagen durch.
- Überprüfen Sie den Schuppen regelmäßig auf Stabilität und stellen Sie sicher, dass der Standort eben ist.
- Seien Sie vorsichtig, wenn Sie mit Teilen hantieren, die Stahlkanten aufweisen.
- Für Aufbau und Handhabung des Schuppens verwenden Sie bitte nur Werkzeuge, die in der Aufbauanleitung aufgelistet sind.
- Vermeiden Sie den Einsatz von Rasenmäher und maschineller Sense im direkten Umfeld des Schuppens.
- Tragen Sie eine Schutzbrille und befolgen Sie bei Verwendung von Elektrowerkzeugen immer die Anweisungen des Herstellers.
- Reinigen Sie den Schuppen mit einem Gartenschlauch und einem milden Reinigungsmittel. Verwenden Sie auf keinen Fall eine harte Bürste und Scheuer- oder Entfettungsmittel sowie öl- oder azetonhaltige Reinigungsmittel, da diese Flecken verursachen oder den Schuppen beschädigen könnten.

- Lagern Sie keine heißen Gegenstände im Schuppen, wie etwa kürzlich benutzte Grills oder Lötlampen, und auch keine flüchtigen Chemikalien.
- Lehnen Sie keine schweren Gegenstände an die Wände des Schuppens, da sich dadurch der gesamte Schuppen verziehen könnte.
- Halten Sie das Dach frei von Schnee und angesammeltem Blattwerk. Große Mengen an Schnee können den Schuppen beschädigen und beim Betreten gefährlich werden.
- Die Windrichtung ist ein wichtiger Faktor, der bei der Aufstellung des Schuppens unbedingt berücksichtigt werden muss. Vermeiden Sie zu hohe Windbelastungen, insbesondere einen hohen Winddruck auf die Türen. Halten Sie die Türen immer geschlossen und verriegelt, wenn der Schuppen nicht genutzt wird, um eine Beschädigung durch Windbelastungen zu vermeiden.
- Betreten Sie auf keinen Fall das Dach des Schuppens..
- Wenden Sie sich bitte an Ihre lokale Behörde und erkundigen Sie sich dort , ob zum Aufbau des Schuppens eine Genehmigung erforderlich ist.

---

## RICHTLIJNEN VOOR ZORG EN VEILIGHEID

- Het tuinhuisje is uitsluitend bedoeld voor opslag. Het is niet ontworpen voor bewoning.
- Het wordt sterk aanbevolen om het tuinhuisje vast te maken aan een immobiel object of in de grond te verankeren door het boren van gaten in de vloer (op de gemarkeerde plaatsen) en het met de geschikte schroeven in de grond te bevestigen (schroeven zijn niet inbegrepen).
- Probeer niet op stormachtige of koude dagen te monteren.
- Controleer regelmatig of het tuinhuisje stabiel en waterpas staat.
- Wees voorzichtig als u werkt met onderdelen met staalranden.
- Gebruik bij de montage of het hanteren van het tuinhuisje alleen de gereedschappen die in de handleiding vermeld staan.
- Vermijd het gebruik van een grasmaaier of mechanische zeis in de buurt van het tuinhuisje.
- Draag een veiligheidsbril en volg altijd de instructies van de fabrikant als u elektrisch gereedschap gebruikt.
- Was het tuinhuisje met een tuinslang of een zacht schoonmaakmiddel. Gebruik geen harde borstel of schuurmiddelen, met inbegrip van ontvetters en schoonmaakmiddelen op basis van olie of aceton, omdat die het tuinhuisje kunnen beschadigen of vlekken achterlaten.
- Niet geen hete voorwerpen, zoals een pas gebruikte grill of branders in het tuinhuisje, en bewaar er ook geen vluchtige stoffen.
- Plaats geen zware voorwerpen tegen de wanden, die daardoor misvormd kunnen raken.
- Houd het dak vrij van opgehoopte sneeuw en bladeren. Grotere hoeveelheden sneeuw op het dak kunnen het tuinhuisje beschadigen, waardoor het betreden gevaarlijk kan zijn.
- De windrichting is een belangrijke factor bij het bepalen van de locatie van het tuinhuisje. Verminder blootstelling aan de wind, in het algemeen, en bijzonder aan de deurzijde. Houd de deuren gesloten en vergrendeld wanneer het tuinhuisje niet in gebruik is om windschade te voorkomen.
- Ga niet op het dak staan.
- Raadpleeg uw plaatselijke autoriteiten om te controleren of een vergunning vereist is voor het plaatsen van het tuinhuisje.

---

## LINEE GUIDA PER LA CURA E LA SICUREZZA

- Il capannone va utilizzato solo per scopi di immagazzinamento. Non è progettato per abitarvi.
- Si raccomanda vivamente di fissare il capanno su un oggetto immobile o ancorandolo al suolo tramite i fori nel pavimento del capannone (nelle posizioni pre-segnalate) ed inserendo viti adeguate nel terreno (le viti non sono incluse).
- Non tentare il montaggio in giornate ventose o fredde.
- Controllate periodicamente il capannone per accertarvi che sia stabile e che sia a livello del terreno.
- Fai attenzione quando maneggi parti con bordi in acciaio.
- Durante il montaggio o la manipolazione del capannone, utilizzate solo gli strumenti elencati nel manuale utente.
- Evitate di utilizzare un tosaerba o una falce meccanica nei pressi del capannone.
- Indossate occhiali di sicurezza e seguite sempre le istruzioni del produttore quando utilizzate utensili elettrici.
- Lavate il capannone con un tubo da giardino o una soluzione detergente delicata. Non utilizzate una spazzola dura o detersivi abrasivi, né sgrassanti e materiali di pulizia per l'olio - o a base di acetone, in quanto questi possono macchiare o danneggiare il capannone.
- Non conservate oggetti caldi, come grill e lampade per saldature né sostanze chimiche volatili nel capannone.
- Evitate di posizionare oggetti pesanti contro le pareti, in quanto ciò potrebbe causare un danneggiamento.
- Mantenete il tetto pulito dalla neve e dalle foglie accumulate. Grandi quantità di neve sul tetto possono danneggiare il capannone, rendendo precaria la struttura.
- La direzione del vento è un fattore importante da considerare quando scegliete la posizione del capannone. Riducete l'esposizione al vento, in generale, in particolare della porta laterale. Tenete le porte chiuse e bloccate quando il capannone non è in uso per prevenire i danni del vento.
- Non salite sul tetto.
- Consultate le autorità locali per verificare se sono necessari dei permessi per metter su il capannone.

---

## ÁPOLÁSI ÉS BIZTONSÁGI IRÁNYMUTATÁSOK

- A menedékház csak tárolásra szolgál. Nem lakhatásra tervezték.
- Erősen ajánlott a menedéket egy mozgatható tárgyhoz rögzíteni, vagy a talajba rögzíteni úgy, hogy lyukat fúr a menedék padlójába (az előzőleg megjelölt helyeken), és megfelelő csavarokat helyez a padlóba (a csavarokat nem tartalmazza).
- Ne próbáljon szerelni szeles vagy hideg napokon.
- Rendszeresen ellenőrizze a menedéket, hogy az stabil és a terület egyenes legyen.
- Legyen körültekintő az acélvégű alkatrészek kezelésénél.
- A menedék összeszerelésekor vagy kezelésénél csak a felhasználói kézikönyvben megadott szerszámokat használja.
- Kerülje a fűnyíró vagy a mechanikus sarló használatát a menedék közelében.
- Viseljen védőszemüveget, és mindig kövesse a gyártó utasításait, amikor elektromos szerszámokat használ.
- Mossa meg a menedéket kerti tömlővel vagy enyhe mosószerrel oldattal. Ne használjon kemény ecsetet vagy súrolószereket, beleértve zsírtalanítókat vagy olaj- vagy acetonalapú tisztítószereket, mert ezek foltot okozhatnak vagy károsíthatják a menedéket.
- Ne tároljon forró tárgyakat, például nemrég használt rácsokat, fáklyákat és illékony vegyszereket a menedékházban.
- Ne helyezzen nehéz tárgyakat a falakhoz, mert ez torzulást okozhat.
- Tartsa a tetőt hó és levelek felhalmozódásától mentesen. A tetőn lévő nagy mennyiségű hó károsíthatja a menedéket, így nem biztonságos belépni.
- A szélirány fontos tényező, amelyet figyelembe kell venni a menedék helyének meghatározásakor. Csökkentse a szélnek való kitettséget általában, különös tekintettel az oldalsó ajtóra. A szélkárak elkerülése érdekében tartsa az ajtókat csukva és zárva, amikor a fedél nincs használatban.
- Ne maradjon a tetőn.
- Konzultáljon a helyi hatóságokkal, hogy megtudja, szükséges-e engedély a menedék építéséhez.

---

## 10-YEAR LIMITED WARRANTY

---

Your Keter shed (the Product) was manufactured from high-quality, recyclable materials under rigorous control and supervision.

Should a problem occur with the Product, please address your claim to Keter customer service on our website ([www.keter.com](http://www.keter.com)) or by phone.

This warranty covers product failure resulting from defects in manufacturing or materials for a period of 10 years from the date of original retail purchase. (The term "defects" is defined as imperfections that impair the use of the Product).

This warranty does not cover defects resulting from normal wear and tear, including, but not limited to, staining, scratches or fractures caused during use, discoloration or fading, rusting, unreasonable use, abuse, negligence, alterations, painting, moving, transporting or relocating the Product, Acts of Nature, including, but not limited to, hail, any type of storm, flood and fire, and consequential or incidental damages.

Assembly and handling not in accordance with the recommendations, guidelines and restrictions as described in the Product's user manual, and usage for commercial or public applications, will void this warranty.

Keter is not responsible for any damage incurred by third parties or damage to or loss of objects inside or near the shed.

Upon submitting proof of purchase and evidence of the claimed product failure, and subject to reporting the failure in a timely manner, Keter, at its sole discretion, will replace defective parts of the Product, or refund you a prorated portion of the purchase price on a straight line depreciated basis for the length of the warranty.

---

## GARANTIE LIMITÉE DE 10 ANS

---

Votre abri de jardin Keter (le Produit) a été fabriqué à partir de matériaux recyclables de grande qualité, en faisant l'objet de contrôles rigoureux et d'une surveillance stricte.

Si un problème devait se présenter avec le produit, veuillez adresser votre réclamation au service clients de Keter sur notre site internet ([www.keter.com](http://www.keter.com)) ou par téléphone.

Cette garantie couvre les dommages du produit découlant d'un défaut de fabrication ou des matériaux pendant une durée de 10 ans à partir de la date d'achat. (Le terme "défaut" est défini comme des imperfections qui nuisent à la bonne utilisation du produit).

Cette garantie ne couvre pas les défauts résultant d'une usure normale, y compris, mais non limitée aux rayures, aux éraflures ou aux bris provoqués par l'utilisation, la décoloration ou l'estompement de la couleur, la rouille, l'utilisation déraisonnable, les abus, la négligence, les altérations, la peinture, les déplacements, le transport ou la relocalisation du produit, les conditions climatiques exceptionnelles y compris, mais non limitée à, la grêle, tout type de tempête, les inondations et incendies, et tous dégâts accidentels ou consécutifs qui y seraient liés.

Un assemblage et une manipulation non conformes aux recommandations, aux instructions et aux restrictions, telles que décrites dans le mode d'emploi du Produit, ainsi que l'utilisation à des fins commerciales ou publiques, annuleront cette garantie.

Keter ne saurait être tenu responsable de tout dégât encouru par une tierce partie ou de tout dégât ou perte d'objets à l'intérieur ou à proximité de l'abri.

Après avoir soumis une preuve d'achat et une preuve du dommage sur le produit détérioré, et à condition d'avoir signalé le dommage dans les délais impartis, Keter, à son absolue discrétion, remplacera les pièces défectueuses du Produit ou vous remboursera une partie du prix d'achat au prorata, amorti sur une base linéaire pour la durée de la garantie.

---

## GARANTÍA LIMITADA DE 10 AÑOS

---

Su caseta Keter (El Producto) ha sido fabricada con materiales reciclables de alta calidad bajo rigurosos controles y supervisión.

En caso de que aparezca un problema con el Producto, por favor, dirija su reclamación al servicio al cliente de Keter en nuestra página web ([www.keter.com](http://www.keter.com)) o por teléfono.

Esta garantía cubre errores fallos de producto por defectos de fabricación o de materiales durante un periodo de 10 años desde la fecha de la compra del producto. (El término "defectos" se define como imperfecciones que afectan al uso del Producto).

Esta garantía no cubre defectos resultantes por el desgaste debido al uso, incluyendo, entre otros, arañazos, rasguños o roturas provocados durante su uso, decoloración, oxidación, uso no razonable, maltrato, negligencia, alteraciones, pintado, mover, transportar o reubicar el Producto, causas climatológicas incluyendo, entre otros, granizo, cualquier tipo de tormenta, inundación e incendio y daños resultantes o accidentales.

El montaje y su manipulación sin seguir las recomendaciones, directrices y restricciones como se describen en el manual del usuario del Producto y su uso para aplicaciones comerciales o públicas anularán esta garantía.

Keter no se hace responsable por ningún daño realizado por terceros o daños o pérdida de objetos dentro o cerca de la caseta.

Al entregar el ticket o factura de compra y prueba del presunto fallo del producto, y sujeto a informar del fallo de manera puntual, Keter, a su discreción, reemplazará las piezas defectuosas del Producto o le reembolsará una parte prorrateada proporcional del precio de compra en función de los años de garantía consumidos.

---

## AUF 10 JAHRE BEGRENZTE GEWÄHRLEISTUNG

---

Ihr Keter-Schuppen (das Produkt) wurde unter genauer Kontrolle und strenger Aufsicht aus hochwertigen und recycelbaren Materialien hergestellt.

Falls Probleme am Produkt auftauchen sollten, adressieren Sie Ihre Ansprüche bitte an den Keter-Kundendienst auf unserer Webseite ([www.keter.com](http://www.keter.com)) oder wenden Sie sich per Telefon an uns.

Die auf 10 Jahre begrenzte Gewährleistung umfasst Herstellungs- oder Materialdefekte am Produkt und gilt ab dem Datum des ursprünglichen Erwerbs. (Der Begriff "Defekte" wird definiert als Beeinträchtigungen, die die Nutzung des Produktes herabsetzen).

Diese Gewährleistung umfasst keine Defekte, die aus normalem Gebrauch resultieren und schließen unter anderem durch die Nutzung des Produktes entstandenen Abrieb, Kratzer oder Risse mit ein sowie Verfärbungen, Rostansatz und Schäden aufgrund von unsachgemäßer Nutzung, Missbrauch, Unachtsamkeit, Abänderungen, Bemalen, das Versetzen oder Transportieren des Produktes und "Naturereignisse" wozu unter anderem Hagelschlag, jegliche Form von Sturm, Flut und Feuer zählen sowie mittelbare und damit verbundene Beschädigungen hierdurch.

Bei Aufbau und Handhabung, die nicht gemäß den Empfehlungen, Vorgaben und Beschränkungen durchgeführt werden, wie sie in der Gebrauchsanleitung zu dem Produkt vermerkt sind, verliert diese Gewährleistung ihre Gültigkeit. Dies gilt auch für einen Gebrauch zu kommerziellen und öffentlichen Zwecken.

Keter ist nicht verantwortlich für Beschädigungen durch Dritte und Schäden an und Verlust von Gegenständen innerhalb oder in der Nähe des Schuppens.

Nach der Einreichung von Kaufnachweis und Beweismaterial für den beanstandeten Defekt am Produkt, vorbehaltlich einer zeitnahen Meldung des Defekts, wird Keter während der gesamten Gewährleistungsdauer nach alleinigem Ermessen fehlerhafte Teile austauschen oder einen anteiligen Betrag des Kaufpreises auf Basis der linearen Abschreibung zurückerstatten.

---

## 10-JAAR BEPERKTE GARANTIE

---

Uw Ketertuinhuysje (het product) is vervaardigd uit hoogwaardige en recyclebare materialen, onder strenge controle en toezicht.

Mocht zich een probleem voordoen met het product, kunt u uw claim naar de klantendienst van Keter sturen via onze website ([www.keter.com](http://www.keter.com)) of per telefoon. Deze garantie dekt het product voor gebreken in de productie of materialen voor een periode van 10 jaar vanaf de datum van de oorspronkelijke aankoop. (De term "gebreken" wordt gedefinieerd als onvolkomenheden die het gebruik van het product schaden).

Deze garantie geldt niet voor defecten die het gevolg zijn van normale slijtage, met inbegrip van, maar niet beperkt tot, schuren, krassen of breuken ontstaan tijdens het gebruik, verkleuring of vervaging van de kleuren, roest, onredelijk gebruik, misbruik, nalatigheid, wijzigingen, verven, vervoeren of verplaatsen van het product, natuurlijke calamiteiten, met inbegrip van, maar niet beperkt tot, hagel, elke vorm van storm, overstroming en brand, en gevolg- of incidentele schade. Bij assemblage en behandeling niet in overeenstemming met de aanbevelingen, richtlijnen en beperkingen zoals beschreven in de gebruiksaanwijzing van het product, en gebruik voor commerciële of publieke toepassingen, vervalt deze garantie.

Keter is niet verantwoordelijk voor enige schade opgelopen door derden of schade aan of verlies van objecten binnen of in de buurt van het tuinhuysje.

Door het indienen van het aankoopbewijs en het bewijs van het geclaimde gebrek aan het product, en onder voorbehoud van een tijdige rapportage van de gebreken, zal Keter, naar eigen goeddunken, defecte onderdelen van het product vervangen of een pro rata deel van de koopprijs terugbetalen van op basis van een lineair afgeschreven bedrag over de duur van de garantie.

---

## 10 ANNI DI GARANZIA LIMITATA

---

Il tuo capannone Keter (il Prodotto) è stato fabbricato con materiali riciclabili di alta qualità sotto un controllo ed una supervisione rigorosi.

In caso di problemi con il prodotto, cortesemente rivolgetevi al servizio clienti Keter sul nostro sito web ([www.keter.com](http://www.keter.com)) o per telefono.

Questa garanzia copre il guasto del prodotto dovuto a difetti di fabbricazione o dei materiali per un periodo di 10 anni dalla data di acquisto originale. (Il termine "difetti" è definito come imperfezioni che compromettono l'uso del prodotto).

Questa garanzia non copre i difetti derivanti da normale usura, inclusi, ma non limitati a, sfregamento, graffi o fratture createsi durante l'uso, scolorimento, ruggine, uso irragionevole, abuso, negligenza, alterazione, pittura, movimento, trasporto o spostamento del prodotto, eventi naturali tra cui, ma non limitati a, grandine, qualsiasi tipo di tempeste, inondazioni e incendi e danni conseguenti o accidentali.

L'assemblaggio e la manipolazione non in conformità con le raccomandazioni, le linee guida e le restrizioni descritte nel manuale utente del prodotto ed il loro utilizzo per applicazioni commerciali o pubbliche renderà nulla questa garanzia.

Keter non è responsabile per eventuali danni subiti da terzi o per danni o smarrimenti di oggetti all'interno o nei pressi del capannone.

Dopo aver inviato la prova di acquisto e la prova del problema del prodotto, soggetto a dichiarazione tempestiva del problema, Keter, a sua esclusiva discrezione, sostituirà le parti difettose del prodotto, o rimborserà una parte proporzionale del prezzo di acquisto su una linea retta basata sull'ammortamento per la durata della garanzia.

---

## 10 ÉVES KORLÁTOZOTT GARANCIA

---

Az Ön Keter menhelyét (a továbbiakban: a termék) manuálisan, kiváló minőségű újrahasznosítható anyagokból, szigorú ellenőrzés és felügyelet mellett készítették. Ha a termékkel kapcsolatos probléma merül fel, kérjük, hogy panaszát a weboldalon a Keter ügyfélszolgálatához intézze ([www.keter.com](http://www.keter.com)) vagy telefonon. Ez a jótállás az eredeti kiskereskedelmi vásárlás dátumától számított 10 évig a gyártási vagy anyaghibákból eredő termékhibákat fedezi. (A „hibák” kifejezés olyan hiányosságokat határoz meg, amelyek veszélyeztetik a termék használatát). Ez a jótállás nem terjed ki a normál kopásból eredő hibákra, beleértve, de nem kizárólag, a használat során, a színváltozás vagy fakulás, az oxidáció, az ésszerűtlen használat, a visszaélés, az elhanyagolás, a módosítások, a festés, az elmozdulás, a szállítás vagy a szállítás során fellépő súrlódást, karcolást vagy törést. a Termék újrapozícionálása, a „természet cselekedetei”, beleértve, de nem kizárólag, a Jégesőt, bármilyen vihart, áradást és tüzet, valamint károkat következményes vagy véletlen. A Termék felhasználói kézikönyvében leírt ajánlásoknak, irányelveknek és korlátozásoknak nem megfelelő összeszerelés és kezelés, valamint kereskedelmi vagy közcélú felhasználás érvényteleníti a garanciát. A Keter nem vállal felelősséget harmadik felek által okozott károkért vagy károkért. a fészkerben vagy annak közelében. A Keter a vásárolt bizonyíték és a meghibásodás igazolásának bemutatásával, valamint a termék meghibásodásának időben történő bejelentésével, a Keter saját belátása szerint folytatja a termék hibás részeinek cseréjét, vagy visszatéríti a vételárral arányos rész, lineárisan, a garancia időtartama alatt.